



FIRE PROTECTION



GALA | *Regulating
Systems*

Company Profile

GALA-Extends Business on a Global Perspective.

GALA company offers a wide range of products and systems in the field of valves, piping, and seismic isolation for applications ranging from equipment for office buildings, fire fighting, heating, water works, sewerage, marine, industrial to top fluid control. Our aim is meaningful contribution to society by providing comfort and safety through our products, technical skills and services!

GALA-Professional Manufacturer of Industrial Valves

GALA have variety products to meet customer demand of different valve. Designing, manufacture and sale of one-stop service is the company's core strengths.

GALA products cover the following industry area:

Water supply system, water treatment, food, chemical, cement, air-conditioning systems, industry engineering, nuclear power, papermaking, Petrochemical Industry, pharmaceutica, Powder Industry, steel industry, sugar refining, textiles and so on. GALA anti-pollution environmental protection industry is one of the major business. GALA provides various valve for wastewater processing and exhaust gas processing.

GALA have wide variety of industrial valves, including following main products:

Fire Protection Valve
Balancing Valve
Butterfly Valve
Gate Valve, Globe Valve, Check Valve, Ball Valve
Strainer
Flexible Rubber Joint
Flexible Stainless Steel Hose, Expansion Joint

Other Valves and fittings are also available from GALA

All products will be designed, manufactured and assembly by GALA.



CONTENTS

Gate Valve

322FF / 345FF Resilient Seated NRS Type-Flanged Ends	1-3
322FG / 345FG Resilient Seated NRS Type-Flange-Groove Ends	4-5
322GG / 345GG Resilient Seated NRS Type-Groove-Groove Ends	6-7
322JJ / 345JJ Resilient Seated OS&Y Type-MJ-MJ Ends	8-9
322FJ / 345FJ Resilient Seated OS&Y Type-Flange-MJ Ends	10-11
333FF / 341FF Resilient Seated OS&Y Type-Flanged Ends	12-14
333FG Resilient Seated OS&Y Type-Flange-Groove Ends	15-16
333GG / 341GG Resilient Seated OS&Y Type-Groove-Groove Ends	17-18
333JJ / 341JJ Resilient Seated OS&Y Type-MJ-MJ Ends	19-20
333FJ / 341FJ Resilient Seated OS&Y Type-Flange-MJ Ends	21-22
Pressure-Temperature Chart	23

Indicator Post

G388 Indicator Post - Underground Type	24
G322 Indicator Post - Underground Type	25
G345 Indicator Post - Underground Type	26
W388 Indicator Post - Wall Type	27
W345 Indicator Post - Wall Type	28

Swing Check Valve

55FF/58FF-365 Resilient Seated Flanged Ends	29-30
50GG/58GG-365 Resilient Seated Grooved Ends	31-32
50GGP/58GGP-365 Resilient Seated Grooved Ends Riser (Shotgun)	33-34
50W Resilient Seated Wafer Ends	35
Pressure-Temperature Chart	36

Y Strainer

70FF Flanged Ends	37
70FG Flange-Groove Ends	38
70GG Groove-Groove Ends	39
Pressure-Temperature Chart	40

Butterfly Valve

25W Resilient Seated Wafer Ends	41
25L Resilient Seated Lug Ends ²	42
5GG Resilient Seated Grooved Ends	43
20GG/22G Resilient Seated Grooved Ends	44
20T/22T Resilient Seated Screwed Ends	45

Air Vent Valve

9712 Air Release Valve	46
------------------------	----

Fire Hydrant

1510 Dry Barrel Fire Hydrant	47
1511 Wet Barrel Fire Hydrant	48

Water Flow Detector With Retard

1042-V Water Flow Detector With Retard	51
1042-T Water Flow Detector With Retard	53

Brass Valve

Test And Drain	55
Hose Valve	56
Angle Valve	57
Ball Valve	58
Fire Department Connections	59

CERTIFICATE

CERTIFICATE OF COMPLIANCE

Certificate Number: 20130703-EX16375
 Report Reference: EX16375-20130701
 Issue Date: 2013-JULY-03

Issued to: GALA RS INC
 SUITE 201
 11200 WESTHEIMER RD
 HOUSTON, TX, 77042, US

This is to certify that representative samples of STRAINERS, PIPELINE Strainers, basket type - 70FF-300, 70FG-300, 70GG-300, 70FF-250, 70FG-250, 70GG-250, 70FF-200, 70FG-200, 70GG-200.

Have been investigated by UL in accordance with the Standard(s) indicated on this Certificate.

Standard(s) for Safety: UL Subject 321 - Outline of Investigation for Pipeline Strainers

Additional Information: See the UL Online Certifications Directory at www.ul.com/database for additional information

Only those products bearing the UL Listing Mark should be considered as being covered by UL's Listing and Follow-Up Service.

The UL Listing Mark generally includes the following elements: the symbol UL in a circle, with the word LISTED, a control number (may be alphanumeric) assigned by UL, and the product category name (product identifier) as indicated in the appropriate UL Directory.

Look for the UL Listing Mark on the product.

David B. Fuller
David B. Fuller, Director, UL Fire Protection Certification Programs
 UL LLC
 Any reproduction of this information without the UL Listing Mark is prohibited. For a complete list of UL's products and services, please visit www.ul.com.

Page 1 of 1

CERTIFICATE OF COMPLIANCE

Certificate Number: 20190506-EX15959
 Report Reference: EX15959-20121023
 Issue Date: 2019-MAY-06

Issued to: TIANJIN GALAXY VALVE CO LTD
 15 TIANHUA RD
 BALITAI INDUSTRIAL AREA
 JINNAN DISTRICT
 TIANJIN
 300350 CHINA

This certificate confirms that representative samples of CHECK VALVES See addendum page for models.

Have been investigated by UL in accordance with the Standard(s) indicated on this Certificate.

Standard(s) for Safety: UL 312 - Check Valves for Fire-Protection Service
 UL CQIRD C312-47 - Check Valves for Fire-Protection Service

Additional Information: See the UL Online Certifications Directory at <https://in.ulrospector.com> for additional information.

This Certificate of Compliance does not provide authorization to apply the UL Mark. Only the UL Follow-Up Services Procedure provides authorization to apply the UL Mark.

Only those products bearing the UL Mark should be considered as being UL Certified and covered under UL's Follow-Up Services.

Look for the UL Certification Mark on the product.

Certificate Program
 UL LLC. Web content are provided as a service of UL LLC. UL LLC is not responsible for the use of the UL Listing Mark.

Certificate of Compliance

This certificate is issued for the following:

AIR RELEASE VALVES

Model 9712
Sizes 1/2, 3/4 and 1 inch NPS

Prepared for:
 Gala RS Inc.
 11200 Westheimer, Suite 201
 Houston, TX 77042
 USA

FM Approvals Class: 1344 Air Release Valves 1/2 Inch through 1 Inch, dated January 2010
 Approval Identification: PR452028 Approval Granted: November 5, 2018

To verify the availability of the Approved product, please refer to www.approvalguide.com

Said Approval is subject to satisfactory field performance, continuing Surveillance Audits, and strict conformity to the constructions as shown in the Approval Guide, an online resource of FM Approvals.

David B. Fuller
 David B. Fuller
 VP, Manager - Fire Protection
 FM Approvals
 1151 Boston-Providence Turnpike
 Norwood, MA 02062 USA

Certificate of Compliance

This certificate is issued for the following:

OS&Y Gate Valve Model 333
NRS Gate Valve Model 322
Check Valve Model 55FF

Prepared for:
 Gala RS Inc.
 11200 Westheimer, Suite 201
 Houston, TX 77042
 FM Approvals Class: 1120/1130
 Approval Identification: 0003062711 Approval Granted: July 20, 2017

To verify the availability of the Approved product, please refer to www.approvalguide.com

Said Approval is subject to satisfactory field performance, continuing Surveillance Audits, and strict conformity to the constructions as shown in the Approval Guide, an online resource of FM Approvals.

David B. Fuller
 David B. Fuller
 VP, Manager - Fire Protection
 FM Approvals
 1151 Boston-Providence Turnpike
 Norwood, MA 02062 USA

Certificate of Compliance

This certificate is issued for the following:

OUTSIDE SCREW & YOKE TYPE (OS&Y) GATE VALVE
 MODELS 399FF-300, 399FF-250, 399FF-200, 399GG-300, 399GG-250, 399GG-200, 399FG-300, 399FG-250, 399FG-200

NON-RISING STEM TYPE (NRS) GATE VALVE
 MODELS 388FF-300, 388FF-250, 388FF-200, 388GG-300, 388GG-250, 388GG-200, 388FG-300, 388FG-250, 388FG-200

INDICATOR POST MODELS G388 AND W388
 SWING CHECK VALVE MODELS 50FF -300, 50FF-250, 50FF-200

Prepared for:
 GALA RS Inc.
 11200 Westheimer
 Suite 201
 Houston, TX 77042
 FM Approvals Class: 1120/1130, 1110, 1210
 Approval Identification: 0003049247 Approval Granted: July 12, 2013

To verify the availability of the Approved product, please refer to www.approvalguide.com

Said Approval is subject to satisfactory field performance, continuing Surveillance Audits, and strict conformity to the constructions as shown in the Approval Guide, an online resource of FM Approvals.

Richard B. Dunn
 Richard B. Dunn
 Group Manager - Fire Protection
 FM Approvals
 1151 Boston-Providence Turnpike
 Norwood, MA 02062
 August 7, 2013
 Date

Gate Valve

Resilient Seated NRS Type-Flanged Ends

Fig. 322FF-300
322FF-250
322FF-200

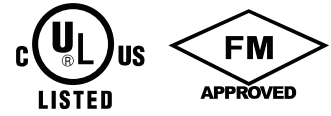

Valve Standard

Conforms to AWWA C515 / BS5163
Fusion bonded coating comply with AWWA C550

Working pressure

200PSI / 250PSI / 300PSI

Working Temperature

-10°C to 120°C

Connection Ends

ANSI B16.1 CLASS125 / B16.42 CLASS150
EN1092-2 PN16

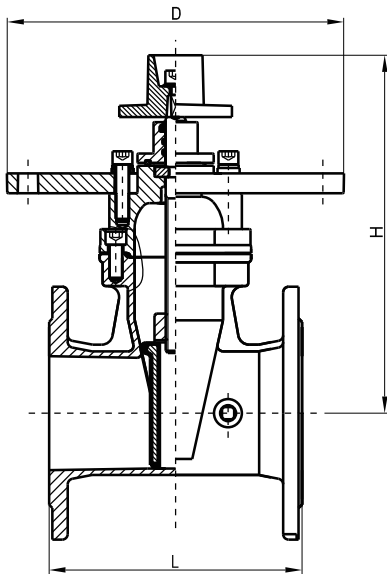

Materials List

Part Name	Material	Specification
Body	Ductile Iron	A536 65-45-12
Wedge Disc	Ductile Iron EPDM Coated	
Disc Nut	Bronze	ASTM B62
Stem	Stainless Steel	AISI 304
Gasket	EPDM	Commercial
Bonnet	Ductile Iron	A536 65-45-12
Thrust Collar	Bronze	ASTM C51100
Gland	Ductile Iron	A536 65-45-12
Wrench Nut	Ductile Iron	A536 65-45-12
Post Plate	Ductile Iron	A536 65-45-12

Dimensions(mm/inch):

SIZE	mm	50	65	80	100	125	150	200	250	300
	inch	2	2 1/2	3	4	5	6	8	10	12
L	mm	178	191	203	229	254	267	292	330	356
	inch	7.00	7.50	8.00	9.00	10.00	10.50	11.50	13.00	14.00
H	mm	279	279	305	324	394	428	537	640	723
	inch	10.98	10.98	12.01	12.76	15.51	16.85	21.14	25.20	28.46
D	mm	305	305	305	305	305	305	305	305	305
	inch	12.01	12.01	12.01	12.01	12.01	12.01	12.01	12.01	12.01

Remark: UL & ULC for 2.5"-12"

Note: Subject to change without prior notice due to products optimization.

Gate Valve

Resilient Seated NRS Type-Flanged-Ends

Fig.345PFF



Handwheel OP

Square Nut OP

Valve Standard

Conforms to AWWA C515 / BS5163
Fusion bonded coating comply with AWWA C550

Working Pressure

365PSI

Working Temperature

-10°C to 120°C

Connection Ends

ANSI 125/150 / EN 1092-2 PN16

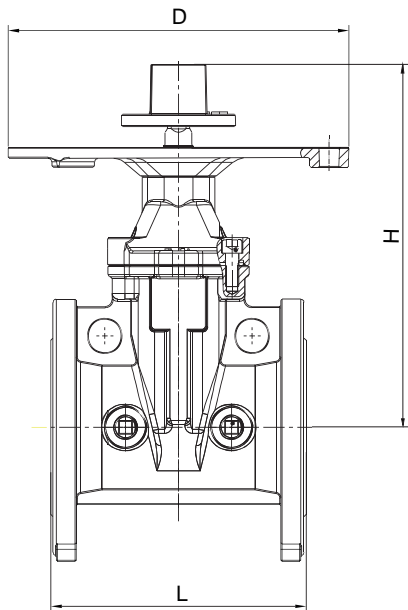

Materials List

Part Name	Material	Specification
Body	Ductile Iron	A536 65-45-12
Wedge Disc	Ductile Iron EPDM Coated	
Disc Nut	Bronze	ASTM B62
Stem	Stainless Steel	AISI 304
Gasket	EPDM	Commercial
Bonnet	Ductile Iron	A536 65-45-12
Thrust Collar	Bronze	ASTM C51100
Gland	Ductile Iron	A536 65-45-12
Wrench Nut	Ductile Iron	A536 65-45-12
Post Plate	Ductile Iron	A536 65-45-12
Handle	Ductile Iron	A536 65-45-12

Dimensions(mm/inch)

Size	mm	50	65	80	100	125	150	200	250	300
	inch	2	2-1/2	3	4	5	6	8	10	12
L		178	191	203	229	254	267	292	330	356
H		263	263	293	326	420	420	506	610	711
D		305	305	305	305	305	305	305	305	305

Note: Subject to change without prior notice due to products optimization.

Gate Valve

Resilient Seated NRS Type-Flanged Ends

Fig. 322FF-250(DN350-DN450)
322FF-200(DN500-DN600)

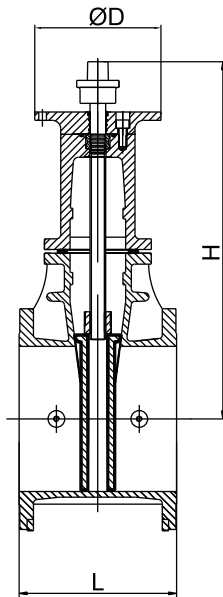

Valve Standard

Conforms to AWWA C515 / BS5163
Fusion bonded coating comply with AWWA C550

Working pressure

200PSI / 250PSI

Working Temperature

-10°C to 120°C

Connection Ends

ANSI B16.1 CLASS125/B16.42 CLASS150
EN1092-2 PN16

Materials List

Part Name	Material	Specification
Body	Ductile Iron	A536 65-45-12
Wedge Disc	Ductile Iron EPDM Coated	
Disc Nut	Bronze	ASTM B62
Stem	Stainless Steel	AISI 304
Gasket	EPDM	Commercial
Bonnet	Ductile Iron	A536 65-45-12
Thrust Collar	Bronze	ASTM C51100
Gland	Ductile Iron	A536 65-45-12
Wrench Nut	Ductile Iron	A536 65-45-12
Post Plate	Ductile Iron	A536 65-45-12

Dimensions(mm/inch):

SIZE	mm	350	400	450	500	600
	inch	14	16	18	20	24
L	mm	381	406	432	457	508
	inch	15.00	15.98	17.01	17.99	20.00
H	mm	862	938	1057	1142	1295
	inch	33.94	36.93	41.61	44.96	50.98
D	mm	305	305	305	305	305
	inch	12.01	12.01	12.01	12.01	12.01

Note: Subject to change without prior notice due to products optimization.

Gate Valve

Resilient Seated NRS Type-Flange-Groove Ends

Fig. 322FG-300
322FG-250
322FG-200

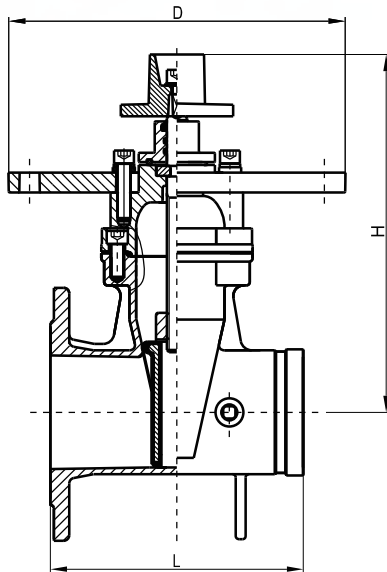

Valve Standard

Conforms to AWWA C515 / BS5163
Fusion bonded coating comply with AWWA C550

Working pressure

200PSI / 250PSI / 300PSI

Working Temperature

-10°C to 120°C

Connection Ends

ANSI B16.1 CLASS125/B16.42 CLASS150
EN1092-2 PN16
AWWA C 606
VDS2100/AS2638.2
GB/T 8260

Materials List

Part Name	Material	Specification
Body	Ductile Iron	A536 65-45-12
Wedge Disc	Ductile Iron EPDM Coated	
Disc Nut	Bronze	ASTM B62
Stem	Stainless Steel	AISI 304
Gasket	EPDM	Commercial
Bonnet	Ductile Iron	A536 65-45-12
Thrust Collar	Bronze	ASTM C51100
Gland	Ductile Iron	A536 65-45-12
Wrench Nut	Ductile Iron	A536 65-45-12
Post Plate	Ductile Iron	A536 65-45-12

Dimensions(mm/inch):

SIZE	mm	50	65	80	100	125	150	200	250	300
	inch	2	2 1/2	3	4	5	6	8	10	12
L	mm	178	191	203	229	254	267	292	330	356
	inch	7.00	7.50	8.00	9.00	10.00	10.50	11.50	13.00	14.00
H	mm	279	279	305	324	394	428	537	640	723
	inch	10.98	10.98	12.01	12.76	15.51	16.85	21.14	25.20	28.46
D	mm	305	305	305	305	305	305	305	305	305
	inch	12.01	12.01	12.01	12.01	12.01	12.01	12.01	12.01	12.01

Remark: UL & ULC for 2.5"-12"

Note: Subject to change without prior notice due to products optimization.

Gate Valve

Resilient Seated NRS Type-Flange-Groove-Ends

Fig.345PFG



Handwheel OP

Square Nut OP

Valve Standard

Conforms to AWWA C515 / BS5163
Fusion bonded coating comply with AWWA C550

Working Pressure

35PSI

Working Temperature

-10°C to 120°C

Connection Ends

ANSI 125/150/EN 1092-2 PN16
AWWA C 606 / GB / T8260 / VDS 2100

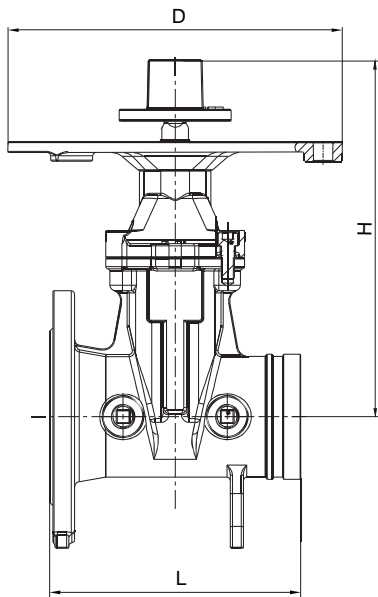

Materials List

Part Name	Material	Specification
Body	Ductile Iron	A536 65-45-12
Wedge Disc	Ductile Iron EPDM Coated	
Disc Nut	Bronze	ASTM B62
Stem	Stainless Steel	AISI 304
Gasket	EPDM	Commercial
Bonnet	Ductile Iron	A536 65-45-12
Thrust Collar	Bronze	ASTM C51100
Gland	Ductile Iron	A536 65-45-12
Wrench Nut	Ductile Iron	A536 65-45-12
Post Plate	Ductile Iron	A536 65-45-12
Handle	Ductile Iron	A536 65-45-12

Dimensions(mm/inch)

Size	mm	50	65	80	100	125	150	200	250	300
	inch	2	2-1/2	3	4	5	6	8	10	12
L		178	191	203	229	254	267	292	330	356
H		263	263	293	326	420	420	506	610	711
D		305	305	305	305	305	305	305	305	305

Note: Subject to change without prior notice due to products optimization.

Gate Valve

Resilient Seated NRS Type-Groove-Groove Ends

Fig. 322GG-300
322GG-250
322GG-200

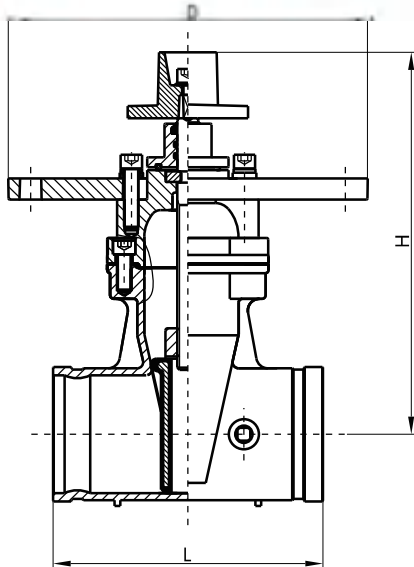

Valve Standard

Conforms to AWWA C515 / BS5163
Fusion bonded coating comply with AWWA C550

Working pressure

200PSI / 250PSI / 300PSI

Working Temperature

-10°C to 120°C

Connection Ends

AWWA C 606
VDS2100/AS2638.2
GB/T 8260

Materials List

Part Name	Material	Specification
Body	Ductile Iron	A536 65-45-12
Wedge Disc	Ductile Iron EPDM Coated	
Disc Nut	Bronze	ASTM B62
Stem	Stainless Steel	AISI 304
Gasket	EPDM	Commercial
Bonnet	Ductile Iron	A536 65-45-12
Thrust Collar	Bronze	ASTM C51100
Gland	Ductile Iron	A536 65-45-12
Wrench Nut	Ductile Iron	A536 65-45-12
Post Plate	Ductile Iron	A536 65-45-12

Dimensions(mm/inch):

SIZE	mm	50	65	80	100	125	150	200	250	300
	inch	2	2 1/2	3	4	5	6	8	10	12
L	mm	178	191	203	229	254	267	292	330	356
	inch	7.00	7.50	8.00	9.00	10.00	10.50	11.50	13.00	14.00
H	mm	279	279	305	324	394	428	537	640	723
	inch	10.98	10.98	12.01	12.76	15.51	16.85	21.14	25.20	28.46
D	mm	305	305	305	305	305	305	305	305	305
	inch	12.01	12.01	12.01	12.01	12.01	12.01	12.01	12.01	12.01

Remark: UL & ULC for 2.5"-12"

Note: Subject to change without prior notice due to products optimization.

Gate Valve

Resilient Seated NRS Type-Groove-Groove-Ends

Fig.345PGG



Handwheel OP

Square Nut OP

Valve Standard

Conforms to AWWA C515 / BS5163
Fusion bonded coating comply with AWWA C550

Working Pressure

365PSI

Working Temperature

-10°C to 120°C

Connection Ends

AWWA C 606 / GB/T 8260 / VDS 2100

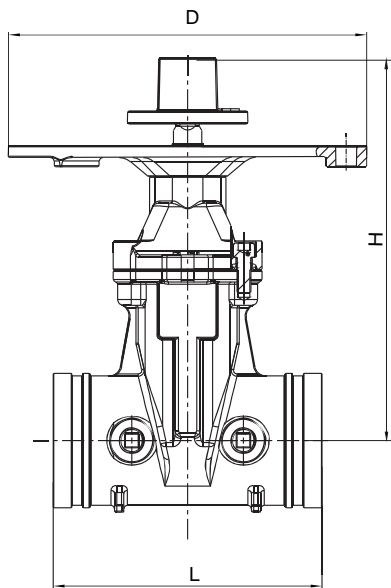

Materials List

Part Name	Material	Specification
Body	Ductile Iron	A536 65-45-12
Wedge Disc	Ductile Iron EPDM Coated	
Disc Nut	Bronze	ASTM B62
Stem	Stainless Steel	AISI 304
Gasket	EPDM	Commercial
Bonnet	Ductile Iron	A536 65-45-12
Thrust Collar	Bronze	ASTM C51100
Gland	Ductile Iron	A536 65-45-12
Wrench Nut	Ductile Iron	A536 65-45-12
Post Plate	Ductile Iron	A536 65-45-12
Handle	Ductile Iron	A536 65-45-12

Dimensions(mm/inch)

Size	mm	50	65	80	100	125	150	200	250	300
	inch	2	2-1/2	3	4	5	6	8	10	12
L		178	191	203	229	254	267	292	330	356
H		263	263	293	326	420	420	506	610	711
D		305	305	305	305	305	305	305	305	305

Note: Subject to change without prior notice due to products optimization.

Gate Valve

Resilient Seated NRS Type-MJ-MJ Ends

Fig. 322JJ-300
322JJ-250
322JJ-200



Valve Standard

Conforms to AWWA C515 / BS5163
Fusion bonded coating comply with AWWA C550

Working pressure

200PSI / 250PSI / 300PSI

Working Temperature

-10°C to 120°C

Connection Ends

AWWA C 153 / A21.11

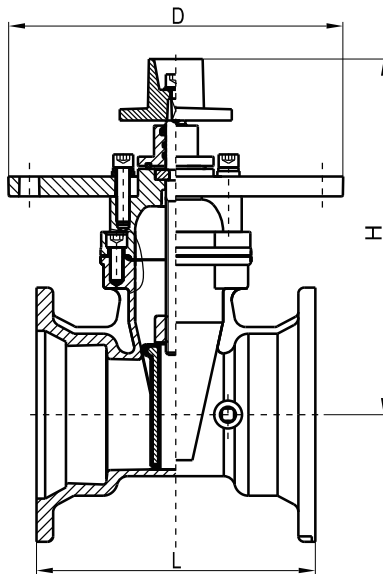

Materials List

Part Name	Material	Specification
Body	Ductile Iron	A536 65-45-12
Wedge Disc	Ductile Iron EPDM Coated	
Disc Nut	Bronze	ASTM B62
Stem	Stainless Steel	AISI 304
Gasket	EPDM	Commercial
Bonnet	Ductile Iron	A536 65-45-12
Thrust Collar	Bronze	ASTM C51100
Gland	Ductile Iron	A536 65-45-12
Wrench Nut	Ductile Iron	A536 65-45-12
Post Plate	Ductile Iron	A536 65-45-12

Dimensions(mm/inch):

SIZE	mm	80	100	150	200	250	300
	inch	3	4	6	8	10	12
L	mm	241	254	292	318	375	378
	inch	9.49	10.00	11.50	12.52	14.76	14.88
H	mm	305	324	428	537	640	723
	inch	12.01	12.76	16.85	21.14	25.20	28.46
D	mm	305	305	305	305	305	305
	inch	12.01	12.01	12.01	12.01	12.01	12.01

Note: Subject to change without prior notice due to products optimization.

Gate Valve

Resilient Seated NRS Type-MJ-MJ Ends

Fig.345PJJ



Handwheel OP

Square Nut OP

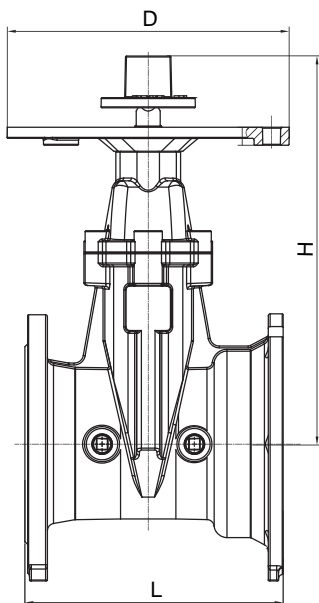

Valve Standard

Conforms to AWWA C515 / BS5163
Fusion bonded coating comply with AWWA C550

Working Pressure

365PSI

Working Temperature

-10°C to 120°C

Connection Ends

ANSI / AWWA C111/A21.11-00

Materials List

Part Name	Material	Specification
Body	Ductile Iron	A536 65-45-12
Wedge Disc	Ductile Iron EPDM Coated	
Disc Nut	Bronze	ASTM B62
Stem	Stainless Steel	AISI 304
Gasket	EPDM	Commercial
Bonnet	Ductile Iron	A536 65-45-12
Thrust Collar	Bronze	ASTM C51100
Gland	Ductile Iron	A536 65-45-12
Wrench Nut	Ductile Iron	A536 65-45-12
Post Plate	Ductile Iron	A536 65-45-12
Handle	Ductile Iron	A536 65-45-12

Dimensions(mm/inch)

Size	mm	80	100	150	200	250	300
	inch	3	4	6	8	10	12
L		241	254	292	318	375	378
H		293	326	420	506	610	711
D		305	305	305	305	305	305

Note: Subject to change without prior notice due to products optimization.

Gate Valve

Resilient Seated NRS Type-Flanged-MJ Ends

Fig. 322FJ-300
322FJ-250
322FJ-200



Valve Standard

Conforms to AWWA C515 / BS5163
Fusion bonded coating comply with AWWA C550

Working pressure

200PSI / 250PSI / 300PSI

Working Temperature

-10°C to 120°C

Connection Ends

AWWA C 153 / A21.11
ANSI B16.1 CLASS125/B16.42 CLASS150
EN1092-2 PN16

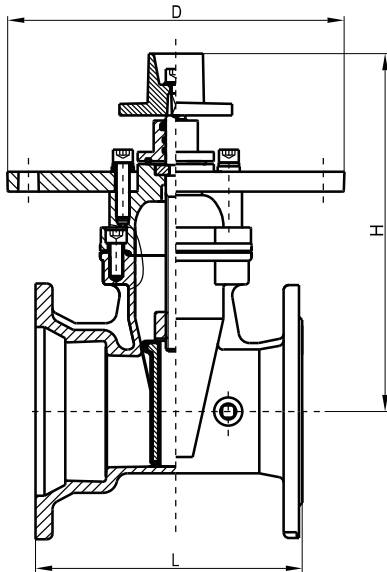

Materials List

Part Name	Material	Specification
Body	Ductile Iron	A536 65-45-12
Wedge Disc	Ductile Iron EPDM Coated	
Disc Nut	Bronze	ASTM B62
Stem	Stainless Steel	AISI 304
Gasket	EPDM	Commercial
Bonnet	Ductile Iron	A536 65-45-12
Thrust Collar	Bronze	ASTM C51100
Gland	Ductile Iron	A536 65-45-12
Wrench Nut	Ductile Iron	A536 65-45-12
Post Plate	Ductile Iron	A536 65-45-12

Dimensions(mm/inch):

SIZE	mm	80	100	150	200	250	300
	inch	3	4	6	8	10	12
L	mm	222.0	241.5	279.5	305.0	352.5	367.0
	inch	8.74	9.51	11.00	12.01	13.88	14.45
H	mm	305	324	428	537	640	723
	inch	12.01	12.76	16.85	21.14	25.20	28.46
D	mm	305	305	305	305	305	305
	inch	12.01	12.01	12.01	12.01	12.01	12.01

Note: Subject to change without prior notice due to products optimization.

Gate Valve

Resilient Seated NRS Type-Flanged-MJ Ends

Fig.345PFJ



Handwheel OP



Square Nut OP

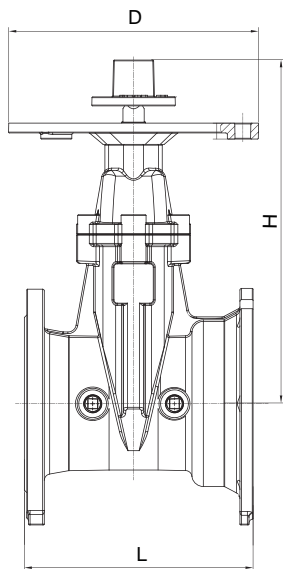

Valve Standard

Conforms to AWWA C515 / BS5163
Fusion bonded coating comply with AWWA C550

Working Pressure

365PSI

Working Temperature

-10°C to 120°C

Connection Ends

ANSI 125/150/EN 1092-2 PN16
ANSI / AWWA C111/A21.11-00

Materials List

Part Name	Material	Specification
Body	Ductile Iron	A536 65-45-12
Wedge Disc	Ductile Iron EPDM Coated	
Disc Nut	Bronze	ASTM B62
Stem	Stainless Steel	AISI 304
Gasket	EPDM	Commercial
Bonnet	Ductile Iron	A536 65-45-12
Thrust Collar	Bronze	ASTM C51100
Gland	Ductile Iron	A536 65-45-12
Wrench Nut	Ductile Iron	A536 65-45-12
Post Plate	Ductile Iron	A536 65-45-12
Handle	Ductile Iron	A536 65-45-12

Dimensions(mm/inch)

Size	mm	80	100	150	200	250	300
	inch	3	4	6	8	10	12
L		222	242	280	305	353	367
H		293	326	420	506	610	711
D		305	305	305	305	305	305

e: Subject to change without prior notice due to products optimization.

Gate Valve

Resilient Seated OS&Y Type-Flanged Ends

Fig. 333FF-300
333FF-250
333FF-200

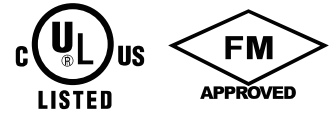

Valve Standard

Conforms to AWWA C515 / BS5163
Fusion bonded coating comply with AWWA C550

Working pressure

200PSI / 250PSI / 300PSI

Working Temperature

-10°C to 120°C

Connection Ends

ANSI B16.1 CLASS125/B16.42 CLASS150
EN1092-2 PN16

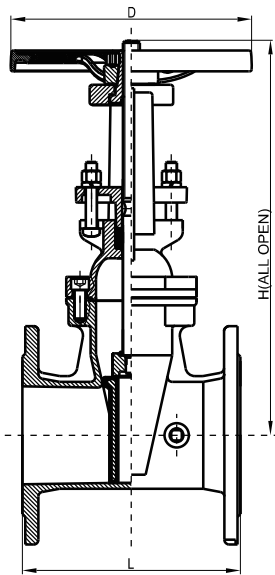

Materials List

Part Name	Material	Specification
Body	Ductile Iron	A536 65-45-12
Wedge	Ductile Iron EPDM Coated	
Wedge Nut	Stainless Steel	AISI 304
Stem	Stainless Steel	AISI 304
Bonnet	Ductile Iron	A536 65-45-12
Gasket	EPDM	Commercial
Packing	PTFE	Non-asbestos
Stem Nut	Bronze	ASTM B62
Handwheel	Ductile Iron	A536 65-45-12

Dimensions(mm/inch):

SIZE	mm	50	65	80	100	125	150	200	250	300
	inch	2	2 1/2	3	4	5	6	8	10	12
L	mm	178.0	191.0	203.0	229.0	254.0	267.0	292.0	330.0	356.0
	inch	7.00	7.50	8.00	9.00	10.00	10.50	11.50	13.00	14.00
H	mm	411	411	462	514	629	709	922	1116	1300
	inch	16.18	16.18	18.19	20.24	24.76	27.91	36.30	43.94	51.18
D	mm	183	183	253	253	306	306	355	445	445
	inch	7.20	7.20	9.96	9.96	12.05	12.05	13.98	17.52	17.52

Note: Subject to change without prior notice due to products optimization.

Gate Valve

Resilient Seated OS&Y Type-Flanged Ends

Fig.341FF

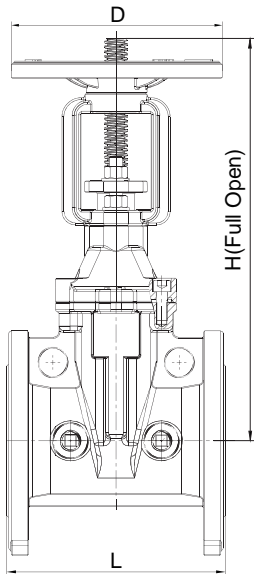

Valve Standard

Conforms to AWWA C515 / BS5163
Fusion bonded coating comply with AWWA C550

Working Pressure

365PSI

Working Temperature

-10°C to 120°C

Connection Ends

ANSI 125/150/EN 1092-2 PN16

Materials List

Part Name	Material	Specification
Body	Ductile Iron	A536 65-45-12
Wedge Disc	Ductile Iron EPDM Coated	
Disc Nut	Bronze	ASTM B62
Stem	Stainless Steel	AISI 304
Gasket	EPDM	Commercial
Bonnet	Ductile Iron	A536 65-45-12
Thrust Collar	Bronze	ASTM C51100
Gland	Ductile Iron	A536 65-45-12
Wrench Nut	Ductile Iron	A536 65-45-12
Post Plate	Ductile Iron	A536 65-45-12

Dimensions(mm/inch)

Size	mm	50	65	80	100	125	150	200	250	300
	inch	2	2-1/2	3	4	5	6	8	10	12
L		178	191	203	229	254	267	292	330	356
H		409	409	463	522	715	715	913	1118	1300
D		160	160	220	220	280	306	370	420	445

Note: Subject to change without prior notice due to products optimization.

Gate Valve

Resilient Seated OS&Y Type-Flanged Ends

Fig. 333FF-250(DN350-DN450)
333FF-200(DN500-DN600)



Valve Standard

Conforms to AWWA C515 / BS5163
Fusion bonded coating comply with AWWA C550

Working pressure

200PSI / 250PSI

Working Temperature

-10°C to 120°C

Connection Ends

ANSI B16.1 CLASS125/B16.42 CLASS150
EN1092-2 PN16

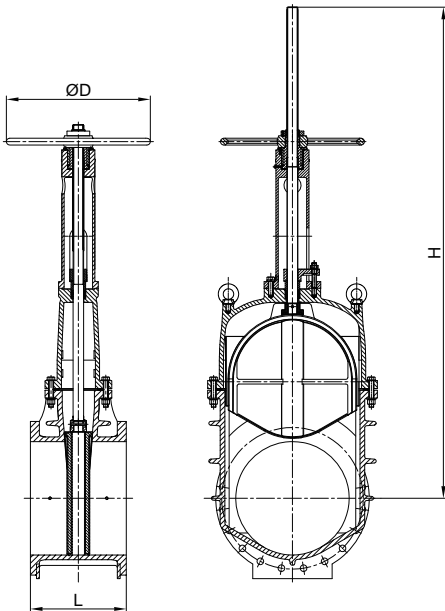

Materials List

Part Name	Material	Specification
Body	Ductile Iron	A536 65-45-12
Wedge	Ductile Iron EPDM Coated	
Wedge Nut	Stainless Steel	AISI 304
Stem	Stainless Steel	AISI 304
Bonnet	Ductile Iron	A536 65-45-12
Gasket	EPDM	Commercial
Packing	PTFE	Non-asbestos
Stem Nut	Bronze	ASTM B62
Handwheel	Ductile Iron	A536 65-45-12

Dimensions(mm/inch):

SIZE	mm	350	400	450	500	600
	inch	14	16	18	20	24
L	mm	381	406	432	457	508
	inch	15.00	15.98	17.01	17.99	20.00
H	mm	1577	1800	2048	2297	2600
	inch	62.09	70.87	80.63	90.43	102.36
D	mm	508	558	610	610	762
	inch	20.00	21.97	24.02	24.02	30.00

Note: Subject to change without prior notice due to products optimization.

Gate Valve

Resilient Seated OS&Y Type-Flange-Groove Ends

Fig. 333FG-300
333FG-250
333FG-200

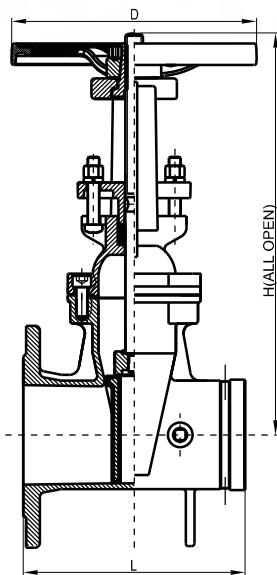
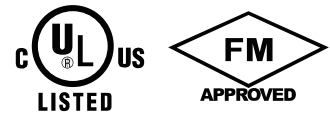

Valve Standard

Conforms to AWWA C515 / BS5163
Fusion bonded coating comply with AWWA C550

Working pressure

200PSI / 250PSI / 300PSI

Working Temperature

-10°C to 120°C

Connection Ends

ANSI B16.1 CLASS125/B16.42 CLASS150
EN1092-2 PN16
AWWA C 606
VDS2100/AS2638.2
GB/T 8260

Materials List

Part Name	Material	Specification
Body	Ductile Iron	A536 65-45-12
Wedge	Ductile Iron EPDM Coated	
Wedge Nut	Stainless Steel	AISI 304
Stem	Stainless Steel	AISI 304
Bonnet	Ductile Iron	A536 65-45-12
Gasket	EPDM	Commercial
Packing	PTFE	Non-asbestos
Stem Nut	Bronze	ASTM B62
Handwheel	Ductile Iron	A536 65-45-12

Dimensions(mm/inch):

SIZE	mm	50	65	80	100	125	150	200	250	300
	inch	2	2 1/2	3	4	5	6	8	10	12
L	mm	178.0	191.0	203.0	229.0	254.0	267.0	292.0	330.0	356.0
	inch	7.00	7.50	8.00	9.00	10.00	10.50	11.50	13.00	14.00
H	mm	411	411	462	514	629	709	922	1116	1300
	inch	16.18	16.18	18.19	20.24	24.76	27.91	36.30	43.94	51.18
D	mm	183	183	253	253	306	306	355	445	445
	inch	7.20	7.20	9.96	9.96	12.05	12.05	13.98	17.52	17.52

Note: Subject to change without prior notice due to products optimization.

Gate Valve

Resilient Seated OS&Y Type-Flanged-Groove Ends

Fig.341FG



Valve Standard

Conforms to AWWA C515 / BS5163
Fusion bonded coating comply with AWWA C550

Working Pressure

365PSI

Working Temperature

-10°C to 120°C

Connection Ends

ANSI 125/150/EN 1092-2 PN16
AWWA C 606 / GB / T8260 / VDS 2100

Materials List

Part Name	Material	Specification
Body	Ductile Iron	A536 65-45-12
Wedge Disc	Ductile Iron EPDM Coated	
Disc Nut	Bronze	ASTM B62
Stem	Stainless Steel	AISI 304
Gasket	EPDM	Commercial
Bonnet	Ductile Iron	A536 65-45-12
Thrust Collar	Bronze	ASTM C51100
Gland	Ductile Iron	A536 65-45-12
Wrench Nut	Ductile Iron	A536 65-45-12
Post Plate	Ductile Iron	A536 65-45-12

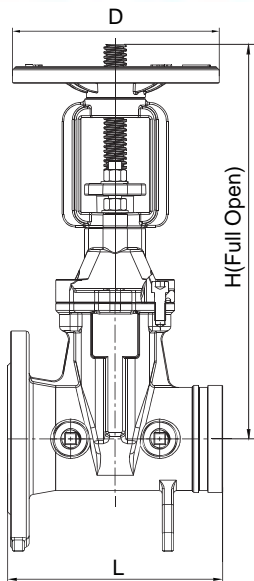

Dimensions(mm/inch)

Size	mm	50	65	80	100	125	150	200	250	300
	inch	2	2-1/2	3	4	5	6	8	10	12
L		178	191	203	229	254	267	292	330	356
H		409	409	463	522	715	715	913	1118	1300
D		160	160	220	220	280	280	306	420	445

Note: Subject to change without prior notice due to products optimization.

Gate Valve

Resilient Seated OS&Y Type-Groove-Groove Ends

Fig. 333GG-300
333GG-250
333GG-200

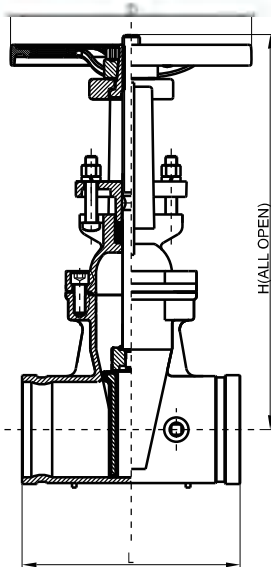

Valve Standard

Conforms to AWWA C515 / BS5163
Fusion bonded coating comply with AWWA C550

Working pressure

200PSI / 250PSI / 300PSI

Working Temperature

-10°C to 120°C

Connection Ends

AWWA C 606
VDS2100/AS2638.2
GB/T 8260

Materials List

Part Name	Material	Specification
Body	Ductile Iron	A536 65-45-12
Wedge	Ductile Iron EPDM Coated	
Wedge Nut	Stainless Steel	AISI304
Stem	Stainless Steel	AISI304
Bonnet	Ductile Iron	A536 65-45-12
Gasket	EPDM	Commercial
Packing	PTFE	Non-asbestos
Stem Nut	Bronze	ASTM B62
Handwheel	Ductile Iron	A536 65-45-12

Dimensions(mm/inch):

SIZE	mm	50	65	80	100	125	150	200	250	300
	inch	2	2 1/2	3	4	5	6	8	10	12
L	mm	178.0	191.0	203.0	229.0	254.0	267.0	292.0	330.0	356.0
	inch	7.00	7.50	8.00	9.00	10.00	10.50	11.50	13.00	14.00
H	mm	411	411	462	514	629	709	922	1116	1300
	inch	16.18	16.18	18.19	20.24	24.76	27.91	36.30	43.94	51.18
D	mm	183	183	253	253	306	306	355	445	445
	inch	7.20	7.20	9.96	9.96	12.05	12.05	13.98	17.52	17.52

Note: Subject to change without prior notice due to products optimization

Gate Valve

Resilient Seated OS&Y Type-Groove-Groove Ends

Fig.341GG

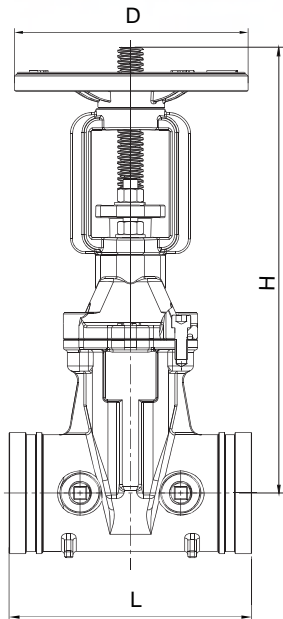

Valve Standard

Conforms to AWWA C515 / BS5163
Fusion bonded coating comply with AWWA C550

Working Pressure

365PSI

Working Temperature

-10°C to 120°C

Connection Ends

AWWA C 606 / GB/T8260 / VDS 2100

Materials List

Part Name	Material	Specification
Body	Ductile Iron	A536 65-45-12
Wedge Disc	Ductile Iron EPDM Coated	
Disc Nut	Bronze	ASTM B62
Stem	Stainless Steel	AISI 304
Gasket	EPDM	Commercial
Bonnet	Ductile Iron	A536 65-45-12
Thrust Collar	Bronze	ASTM C51100
Gland	Ductile Iron	A536 65-45-12
Wrench Nut	Ductile Iron	A536 65-45-12
Post Plate	Ductile Iron	A536 65-45-12

Dimensions(mm/inch)

Size	mm	50	65	80	100	125	150	200	250	300
	inch	2	2-1/2	3	4	5	6	8	10	12
L		178	191	203	229	254	267	292	330	356
H		409	409	463	522	715	715	913	1118	1300
D		160	160	220	220	280	306	370	420	445

Note: Subject to change without prior notice due to products optimization.

Gate Valve

Resilient Seated OS&Y Type-MJ-MJ Ends

Fig. 333JJ-300
333JJ-250
333JJ-200



Valve Standard

Conforms to AWWA C515 / BS5163
Fusion bonded coating comply with AWWA C550

Working pressure

200PSI / 250PSI / 300PSI

Working Temperature

-10°C to 120°C

Connection Ends

AWWA C153/A21.11

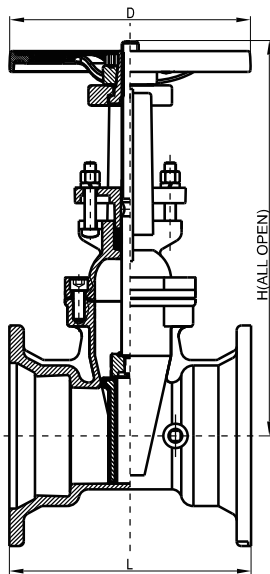

Materials List

Part Name	Material	Specification
Body	Ductile Iron	A536 65-45-12
Wedge	Ductile Iron EPDM Coated	
Wedge Nut	Stainless Steel	AISI304
Stem	Stainless Steel	AISI304
Bonnet	Ductile Iron	A536 65-45-12
Gasket	EPDM	Commercial
Packing	PTFE	Non-asbestos
Stem Nut	Bronze	ASTM B62
Handwheel	Ductile Iron	A536 65-45-12

Dimensions(mm/inch):

SIZE	mm	80	100	150	200	250	300
	inch	3	4	6	8	10	12
L	mm	241	254	292	318	375	378
	inch	9.49	10.00	11.50	12.52	14.76	14.88
H	mm	462	514	709	922	1116	1300
	inch	18.19	20.24	27.91	36.30	43.94	51.18
D	mm	253	253	306	355	445	445
	inch	9.96	9.96	12.05	13.98	17.52	17.52

Note: Subject to change without prior notice due to products optimization.

Gate Valve

Resilient Seated OS&Y Type-MJ-MJ Ends

Fig.341JJ

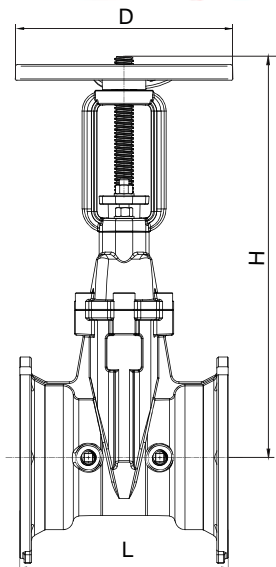

Valve Standard

Conforms to AWWA C515 / BS5163
Fusion bonded coating comply with AWWA C550

Working Pressure

365PSI

Working Temperature

-10°C to 120°C

Connection Ends

AWWA C 606
ANSI / AWWA C111/A21.11-00

Materials List

Part Name	Material	Specification
Body	Ductile Iron	A536 65-45-12
Wedge Disc	Ductile Iron EPDM Coated	
Disc Nut	Bronze	ASTM B62
Stem	Stainless Steel	AISI 304
Gasket	EPDM	Commercial
Bonnet	Ductile Iron	A536 65-45-12
Thrust Collar	Bronze	ASTM C51100
Gland	Ductile Iron	A536 65-45-12
Wrench Nut	Ductile Iron	A536 65-45-12
Post Plate	Ductile Iron	A536 65-45-12

Dimensions(mm/inch)

Size	mm	80	100	150	200	250	300
	inch	3	4	6	8	10	12
L		241	254	292	318	375	378
H		463	522	715	913	1118	1300
D		220	220	306	370	420	445

Note: Subject to change without prior notice due to products optimization.

Gate Valve

Resilient Seated OS&Y Type-Flanged-MJ Ends

Fig. 333FJ-300
333FJ-250
333FJ-200



Valve Standard

Conforms to AWWA C515 / BS5163
Fusion bonded coating comply with AWWA C550

Working pressure

200PSI / 250PSI / 300PSI

Working Temperature

-10°C to 120°C

Connection Ends

AWWA C153/A21.11
ANSI B16.1 CLASS125/B16.42 CLASS150
EN1092-2 PN16

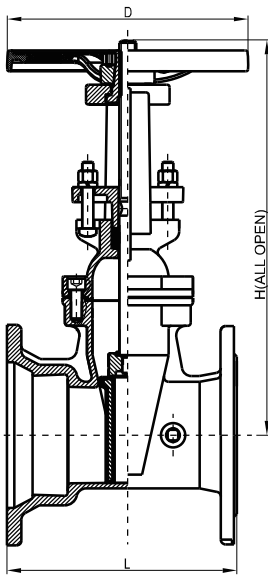

Materials List

Part Name	Material	Specification
Body	Ductile Iron	A536 65-45-12
Wedge	Ductile Iron EPDM Coated	
Wedge Nut	Stainless Steel	AISI304
Stem	Stainless Steel	AISI304
Bonnet	Ductile Iron	A536 65-45-12
Gasket	EPDM	Commercial
Packing	PTFE	Non-asbestos
Stem Nut	Bronze	ASTM B62
Handwheel	Ductile Iron	A536 65-45-12

Dimensions(mm/inch):

SIZE	mm	80	100	150	200	250	300
	inch	3	4	6	8	10	12
L	mm	222	241.5	279.5	305	352.5	367
	inch	8.74	9.51	11.00	12.01	13.88	14.45
H	mm	462	514	709	922	1116	1300
	inch	18.19	20.24	27.91	36.30	43.94	51.18
D	mm	253	253	306	355	445	445
	inch	9.96	9.96	12.05	13.98	17.52	17.52

Note: Subject to change without prior notice due to products optimization.

Gate Valve

Resilient Seated OS&Y Type-Flanged-MJ Ends

Fig.341FJ

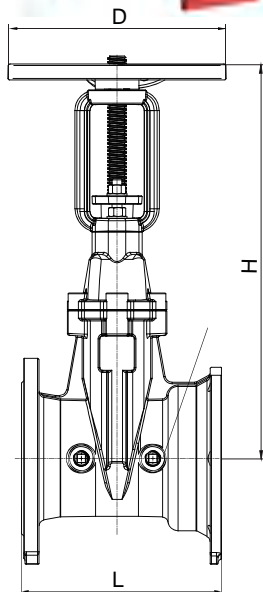

Valve Standard

Conforms to AWWA C515 / BS5163
Fusion bonded coating comply with AWWA C550

Working Pressure

365PSI

Working Temperature

-10°C to 120°C

Connection Ends

ANSI 125/150/EN 1092-2 PN16
ANSI / AWWA C111/A21.11-00

Materials List

Part Name	Material	Specification
Body	Ductile Iron	A536 65-45-12
Wedge Disc	Ductile Iron EPDM Coated	
Disc Nut	Bronze	ASTM B62
Stem	Stainless Steel	AISI 304
Gasket	EPDM	Commercial
Bonnet	Ductile Iron	A536 65-45-12
Thrust Collar	Bronze	ASTM C51100
Gland	Ductile Iron	A536 65-45-12
Wrench Nut	Ductile Iron	A536 65-45-12
Post Plate	Ductile Iron	A536 65-45-12

Dimensions(mm/inch)

Size	mm	80	100	150	200	250	300
	inch	3	4	6	8	10	12
L		222	242	280	305	353	367
H		463	522	715	913	1118	1300
D		220	220	306	370	420	445

Note: Subject to change without prior notice due to products optimization.

Gate Valve

Pressure-Temperature Chart

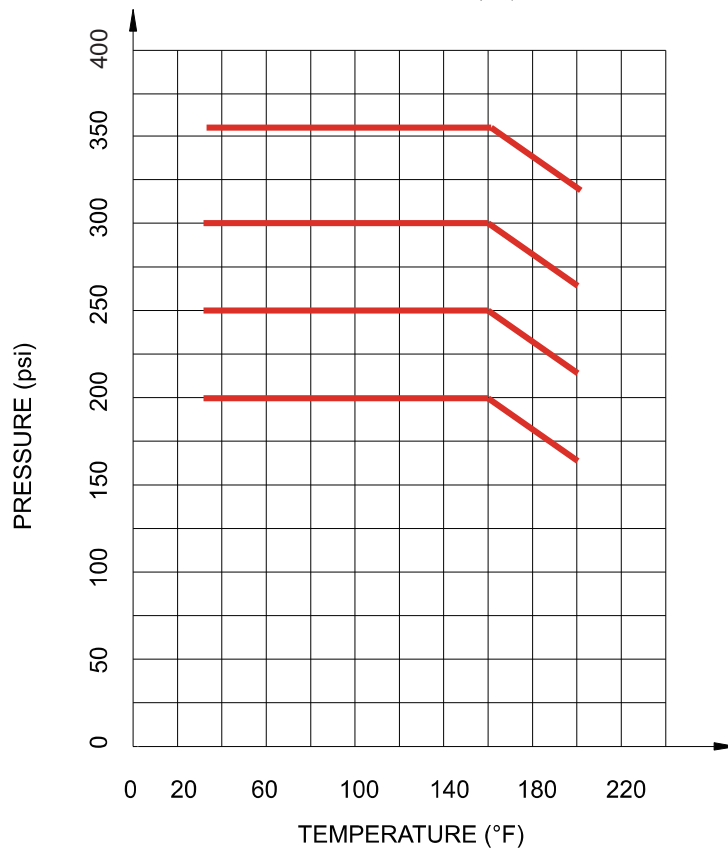
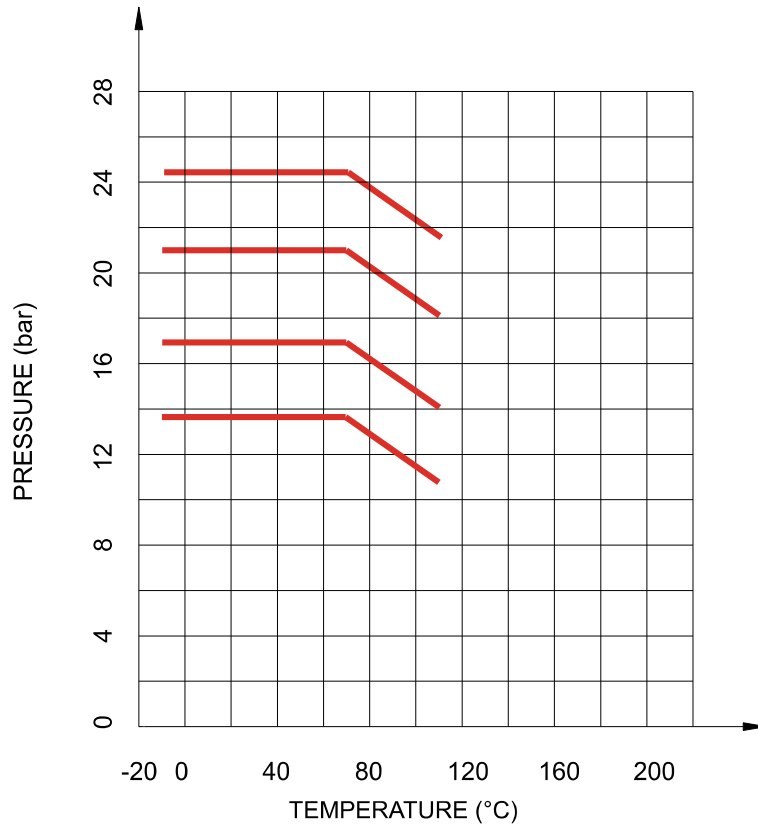

Note: Subject to change without prior notice due to products optimization.

Indicator Post

Indicator Post - Underground Type

Fig.G388

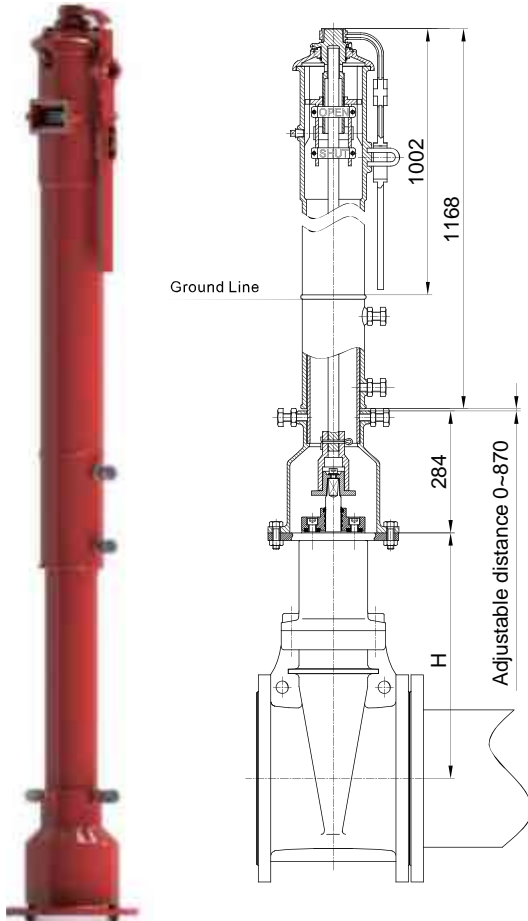

Materials List

Description	Material
Locking Wrench	ASTM A536
Operating Nut	ASTM A351 CF8
Hex Nut Screw	ASTM A105
Hex Nut	ASTM A105
Snap Ring	AISI 066
Target Carrier Nut	ASTM A351 CF8
Target	ASTM B108
Hex Cap Screw	ASTM A105
Window Glass	LEXAN-UN
Window Glass Gasket	PTFE
Hex Cap Screw	ASTM A105
Hex Nut	ASTM A105
Body	ASTM A536
Hex Cap Screw	ASTM A105
Hex Nut	ASTM A105
Base Flange	ASTM A536
Hex Cap Screw	ASTM A105
Hex Nut	ASTM A105
Crane Coupling	ASTM A536
Cotter Pin	AISI 304
Stand Pipe	ASTM A53
Stem	AISI 1045
Plug	AISI 304
Cover	ASTM A536
Cross Recessed Countersunk Head Screw	ASTM 304
Locking Nose	ASTM 307 B
Window Cover	ASTM A307B

Valve Standard

Fusion bonded coating comply with AWWA C550

Field Adjustment:

1. Remove the top section from the top of the Indicator Post assembly
2. Cut the required length off the bottom of the Standpipe for the Ground Line to match up with Standpipe Ground Line mark.
3. Set the "OPEN" and "SHUT" targets for the appropriate valve size.
4. Reattach the Top Section to the top of the Indicator Post assembly.
5. Design and dimensions are subject to change without notice.

Dimensions(mm):

SIZE	2"	2½"	3"	4"	5"	6"	8"	10"	12"
Min.Bury Depth	713	713	733	757	818	852	937	1032	1118
Max.Bury Depth	1583	1583	1603	1627	1688	1722	1807	1902	1988
H	173	173	193	217	278	312	397	492	578

Note: Subject to change without prior notice due to products optimization.

Indicator Post

Indicator Post - Underground Type

Fig.G322

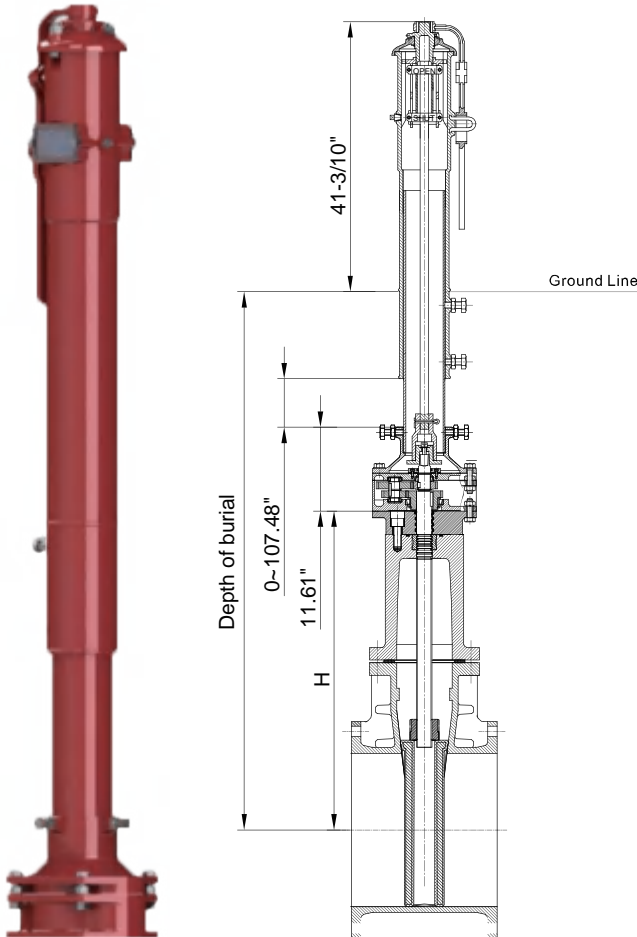

Materials List

Description	Material
Locking Wrench	ASTM A536
Operating Nut	ASTM A351 CF8
Bolt	ASTM A105
Nut	ASTM A105
Flat Washer	ASTM A105
Shap Ring	AISI 606
Taget Carrier Nut	ASTM A351 CF8
Target	ASTM B108
Bolt	ASTM A105
Flat Washer	ASTM A105
Window Gland	ASTM A307B
Window Glass	LEXAN-UN STABILIZE
Gasket	EPDM
Bolt	ASTM A105
Spring Washer	ASTM A105
Nut	ASTM A105
Body	ASTM A536
Bolt	ASTM A105
Nut	ASTM A105
Base Flange	ASTM A126B
Crane Coupling	ASTM A536
Cotter Pin	AISI 304
Stand Pipe	ASTM A53
Stem 1" Square	AISI 1045
Plug	AISI 304
Top Cover	ASTM A126B
Screw	AISI 304
Lock Nose	ASTM A307B
Reducer	PARTS
Bolt	ASTM A105
Nut	ASTM A105
Wrench Nut	ASTM A536
Washer	AISI 304
Hex. Socket Cap Screw	AISI 304
Spring Washer	AISI 304

Valve Standard

Fusion bonded coating comply with AWWA C550

Field Adjustment:

1. Remove the top section from the top of the Indicator Post assembly
2. Cut the required length off the bottom of the Standpipe for the Ground Line to match up with Standpipe Ground Line mark.
3. Set the "OPEN" and "SHUT" targets for the appropriate valve size.
4. Reattach the Top Section to the top of the Indicator Post assembly.
5. Design and dimensions are subject to change without notice.

Dimensions(mm):

SIZE	14"	16"	18"	20"	24"
Min.Bury Depth	1292	1367	1487	1572	1724
Max.Bury Depth	4022	4097	4217	4302	4454
H	741	816	936	1021	1173

Note: Subject to change without prior notice due to products optimization.

Indicator Post

Underground Type

Fig.G345

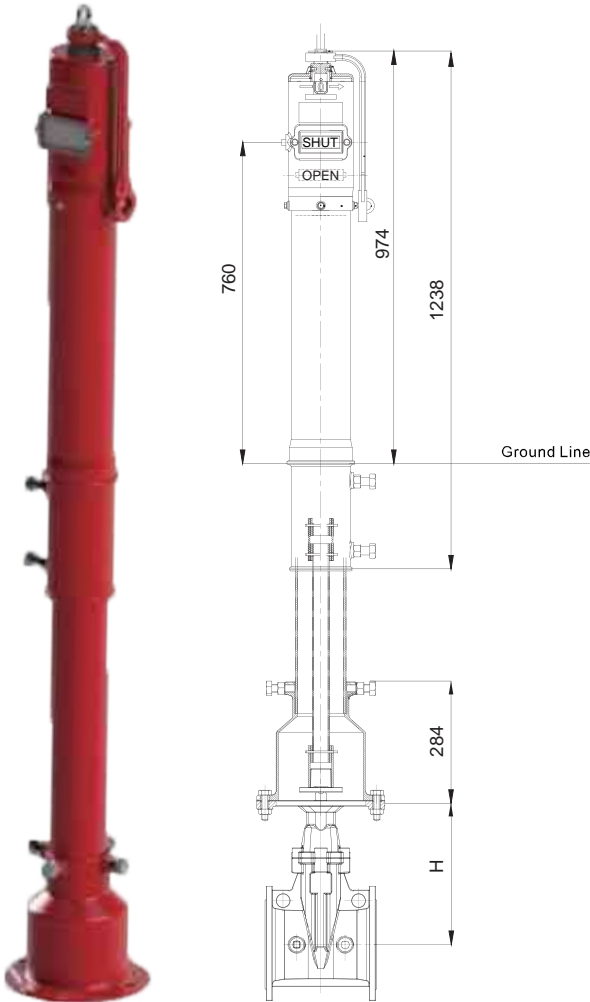

Materials List

Description	Material
Hex Nut	STEEL/SS304
Hex Bolt	STEEL/SS304
Screw	STEEL/SS304
Plug	ASTM SS304
Body	STEEL/SS304
Pedestal	ASTM A536 65-45-12
Square Tube	AISI 1045
Cotter	WCB/SS304
Hoisting Ring	AISI 1045
Square Tube	AISI 1045
Support Barrel	ASTM A53
Lower Barrel-Second	ASTM A536 65-45-12
Lower Barrel-First	ASTM A536 65-45-12
Shut Indicator	ASTM 2024
Open Indicator	ASTM 2024
Seal Ring	EPDM
Plat Washer	STEEL/SS304
Hex Bolt	STEEL/SS304
Window	LEXAN-UN SATBLIZED
Window Cover	ASTM A307B
Body	ASTM A536 65-45-12
Operating Screw	ASTM SS304
Pin	STEEL/SS304
Retainer Ring	65Mn
Dust Cap	EPDM
Operating Nut	ASTM A536 65-45-12
Wrench	ASTM A536 65-45-12

Field Adjustment:

- 1.Remove the top section from the top of the indicator post assembly.
- 2.Cut the required length off the bottom of the Standpipe for the Ground Line to match up with Standpipe Ground Line mark.
- 3.Set the "OPEN" and "SHUT" targets for the appropriate valve size.
- 4.Reattach the Top Section to the top of the indicator Post assembly.

Dimensions(mm):

SIZE	2"	2½"	3"	4"	5"	6"	8"	10"	12"
Min.Bury Depth	623	623	643	667	728	762	847	942	1028
Max.Bury Depth	1493	1493	1513	1537	1598	1632	1717	1812	1898
H	196	196	224	252	343	343	423	534	613

Note: Subject to change without prior notice due to products optimization.

Indicator Post

Indicator Post - Wall Type

Fig.W388

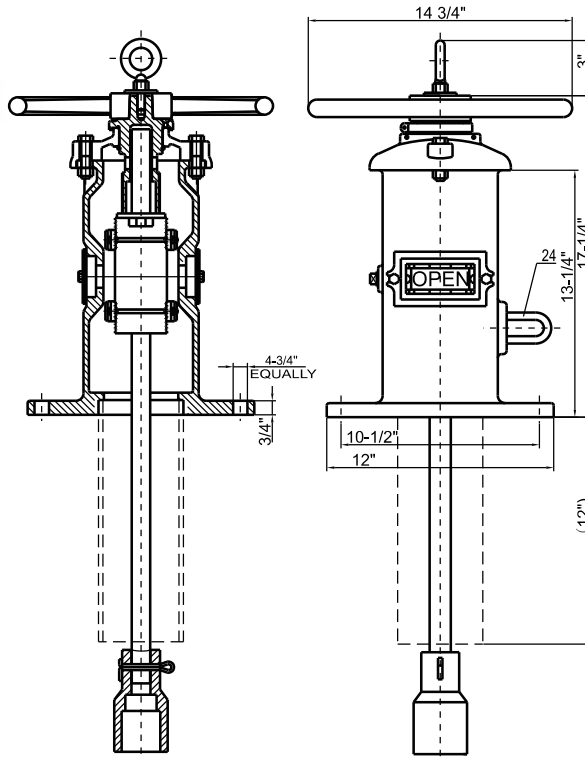

Valve Standard:

Fusion bonded coating comply with AWWA C550.

Field Adjustment:

1. Remove the top section from the top of the Indicator Post assembly.
2. Set the "OPEN" and "SHUT" targets for the appropriate valves size.
3. Reattach the Top Section to the top of the Indicator Post assembly
4. Design and materials are subject to change without notice.

Materials List

Description	Material
Lifting Eyey Bolt	ASTM A105
Hex Nut	ASTM A105
Washer	ASTM A105
Hand Wheel	ASTM A536
Operating Nut	ASTM B62/AISI 304
Hex Cap Screw	ASTM A105
Hex Nut	ASTM A105
Snap Ring	AISI 066
Target Carrier Nut	ASTM B62/AISI 304
Target	ASTM B108
Hex Cap Screw	ASTM A105
Window Glass	LEXAN-UN

Description	Material
Window Glass Gasket	PTFE
Hex Cap Screw	ASTM A105
Hex Nut	ASTM A105
Body	ASTM A536
Stand Pipe	ASTM A53
Stem	AISI 1045
Cotter Pin	AISI 304
Crane Coupling	ASTM A536
Plug	AISI 304
Cover	ASTM A126B
Cross Recessed Countersunk Head Screw	AISI 304
Locking Nose	ASTM A307B

Note: Subject to change without prior notice due to products optimization.

Indicator Post

Wall Type

Fig.W345

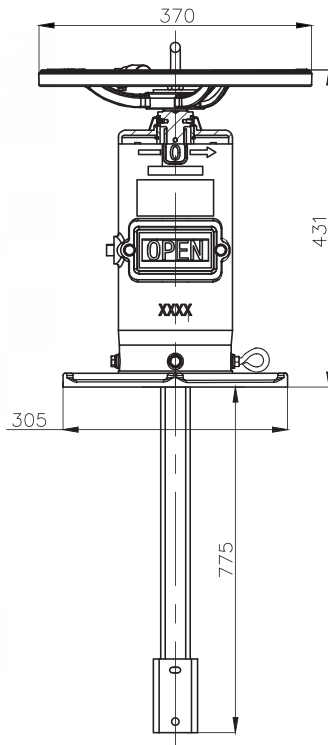

Materials List

Description	Material
Hoisting Ring	ASTM A105
Hex Nut	ASTM A105
Hand Wheel	ASTM A536
Gasket	ASTM SS304
Operating Nut	ASTM A536
Dust Cap	EPDM
Rethiner Ring	65Mn
Pin	STEEL/SS304
Operating Screw	ASTM SS304
Body	ASTM A536
Window Cover	ASTM A307B
Window	EXAN-UN SATBLIZED
Hex Bolt	STEEL/SS304
Plat Washer	STEEL/SS304
Seal Ring	EPDM
Open Indicator	ASTM 2024
Shut Indicator	ASTM 2024
Flange	ASTM A536
Square Tube	AISI 1045
Handle	Parts
Screw	STEEL/SS304
Plug	ASTM SS304
Cotter	STEEL/SS304
Plat Washer	STEEL/SS304
Screw	STEEL/SS304
Hex Nut	STEEL/SS304

Field Adjustment:

- 1.Remove the top section from the top of the indicator post assembly.
- 2.Set the“OPEN” and “SHUT” targets for the apporprate valve size .
- 3.Reattach the Top Section to the top of the indicator Post assembly.

Note: Subject to change without prior notice due to products optimization,

Swing Check Valve

Resilient Seated Flanged Ends

Fig. 55FF-300
55FF-250
55FF-200



Valve Standard

Conforms to AWWA C508, Clear Waterway
Fusion bonded coating comply with AWWA C550

Working pressure

200PSI / 250PSI / 300PSI

Working Temperature

-10°C to 110°C

Flanged Ends

ANSI B16.1 CLASS125/B16.42 CLASS150/B16.1 CLASS250
EN1092-2 PN10/PN16/PN25
BS10 Table D/Table E

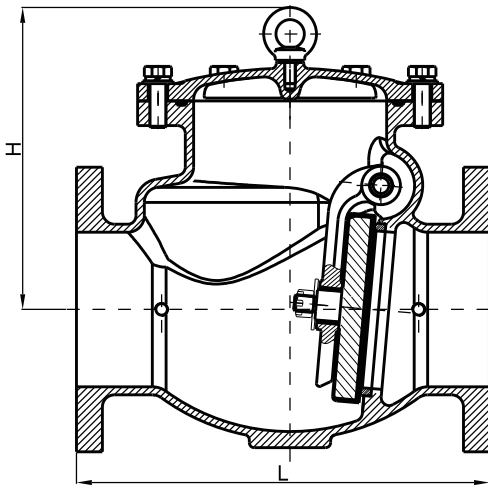

Materials List

Part Name	Material	Specification
Body	Ductile Iron	ASTM A536 65-45-12
Cover	Ductile Iron	ASTM A536 65-45-12
Clapper	Carbon Steel	A36+SS304+EPDM
Clapper Arm	Ductile Iron	ASTM A536 65-45-12
Hinge Pin	Stainless Steel	AISI 304
Seat	Bronze	ASTM C84400

Dimensions(mm/inch)

SIZE	mm	50	65	80	100	125	150	200	250	300
	inch	2	2½	3	4	5	6	8	10	12
L	mm	203	254	279	330	356	406	495	559	660
	inch	8	10	11	13	14	16	19.5	22	26
H	mm	117	128	132.5	222.5	290	297	365	417.5	453
	inch	4.61	5.04	5.22	8.76	11.42	11.69	14.37	16.44	17.83

Note: Subject to change without prior notice due to products optimization.

Swing Check Valve

Resilient Seated Flanged Ends

Fig. 58FF-365



Valve Standard

Conforms to AWWA C508, Clear Waterway
Fusion bonded coating comply with AWWA C550

Working pressure

365PSI

Working Temperature

0°C to 80°C

Flanged Ends

ANSI B16.1 CLASS125/B16.42 CLASS150/B16.1 CLASS250
EN1092-2 PN10/PN16
BS10 Table D/Table E

Materials List

Part Name	Material	Specification
Body	Ductile Iron	ASTM A536 65-45-12
Clapper	Ductile Iron	ASTM A536 65-45-12
Seat	Bronze	ASTM C83600
Disc Sealing Ring	EPDM	
Shaft	Stainless Steel	AISI 304
Pressing Plate	Stainless Steel	AISI 304

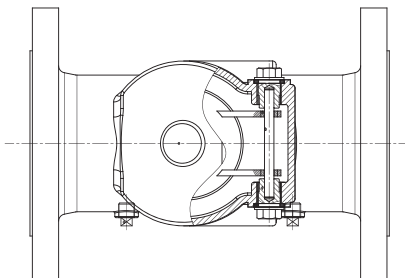
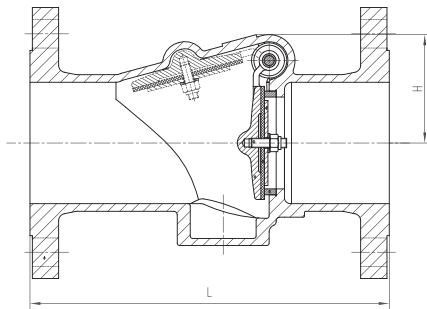
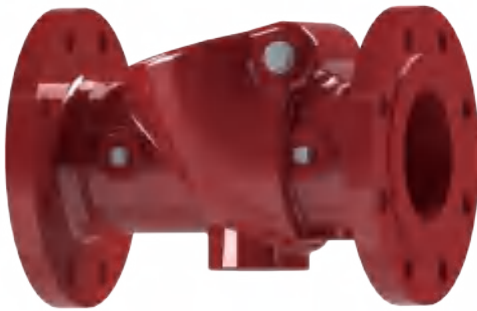

Dimensions(mm/inch)

SIZE	mm	50	65	80	100	125	150	200	250	300
	inch	2	2½	3	4	5	6	8	10	12
L	mm	203	222	241	305	356	394	457	533	610
	inch	8	8.7	9.5	12	14	15.5	18	21	24
H	mm	80	85	93	108	121	199	233	274	306
	inch	3	3.3	3.7	4	4.7	7.8	9.2	10.8	12

Note: Subject to change without prior notice due to products optimization.

Swing Check Valve

Resilient Seated Grooved Ends

Fig. 50GG-365
50GG-300
50GG-250
50GG-200

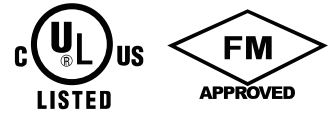

Valve Standard

Fusion bonded coating comply with AWWA C550

Features

- Can be installed horizontally or vertically (with upward flow)
- Convenient to install and maintain
- Low pressure drop

Working pressure

200PSI / 250PSI / 300PSI / 365PSI

Working Temperature

0°C to 80°C

Connection Ends

AWWA C 606 / GB/T 8260 / VDS2100

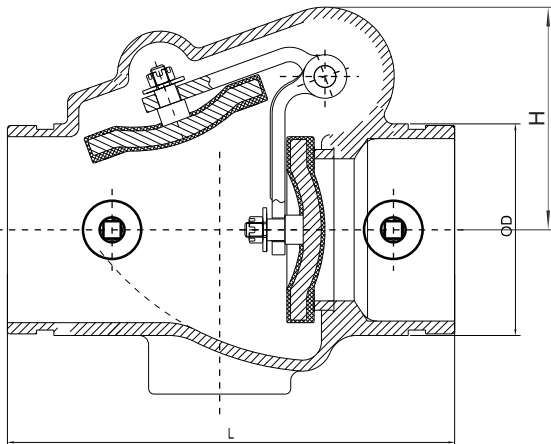

Materials List

Part Name	Material	Specification
Body	Ductile Iron	ASTM A536 65-45-12
Seat	Bronze	ASTM B62 C83600
Clapper	Q235+SS304+EPDM	
Clapper Arm	Stainless Steel	ASTM A351 CF8
Washer	Stainless Steel	AISI 304
Hexagonal Slot Thin Nut	Stainless Steel	AISI 304
Split Pin	Stainless Steel	AISI 304

Dimensions(mm/inch)

SIZE	mm	50	65	80	100	125	150	200	250	300
	inch	2	2½	3	4	5	6	8	10	12
L	mm	169	203	213	245	267	292	356	432	495
OD	mm	60.3	73.0/76.1	88.9	114.3	139.7/141.3	165.1/168.3	219.1	273	323.85
H	mm	79.3	85.3	93	103	121	142	233	274	306

Note: Subject to change without prior notice due to products optimization.

Swing Check Valve

Resilient Seated Grooved Ends

Fig. 58GG-365



Valve Standard

Fusion bonded coating comply with AWWA C550

Features

- Can be installed horizontally or vertically (with upward flow)
- Convenient to install and maintain
- Low pressure drop

Working pressure

365PSI

Working Temperature

0°C to 80°C

Connection Ends

AWWA C 606 / GB/T 8260 / VDS2100

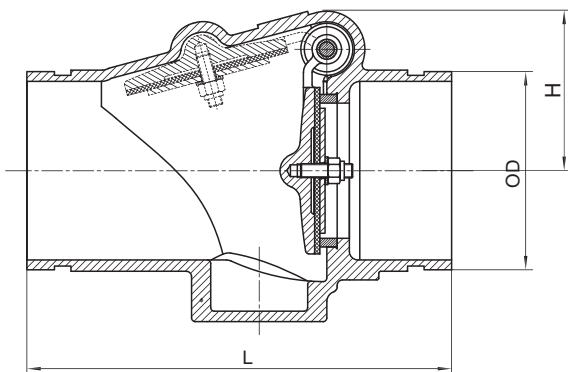

Materials List

Part Name	Material	Specification
Body	Ductile Iron	ASTM A536 65-45-12
Clapper	Ductile Iron	ASTM A536 65-45-12
Seat	Bronze	ASTM C83600
Disc Sealing Ring	EPDM	
Shaft	Stainless Steel	AISI 304
Pressing Plate	Stainless Steel	AISI 304

Dimensions(mm/inch)

SIZE	mm	50	65	80	100	125	150	200	250	300
	inch	2	2½	3	4	5	6	8	10	12
L	mm	169	203	213	245	267	292	356	432	495
OD	mm	60.3	73/76.1	88.9	114.3	139.7/141.3	168.3	219.1	273	323.9
H	mm	79.3	85.3	93	103	121	142	233	274	306

Note: Subject to change without prior notice due to products optimization.

Swing Check Valve

Resilient Seated Grooved Ends Riser (Shotgun)

Fig. 50GGP-365
50GGP-300
50GGP-250
50GGP-200

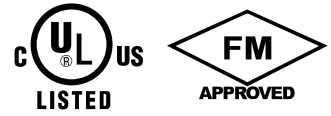

Valve Standard

Fusion bonded coating comply with AWWA C550

Features

- Can be installed horizontally or vertically (with upward flow)
- Convenient to install and maintain
- Low pressure drop

Working pressure

365PSI

Working Temperature

0°C to 80°C

Connection Ends

AWWA C 606 / GB/T 8260 / VDS2100

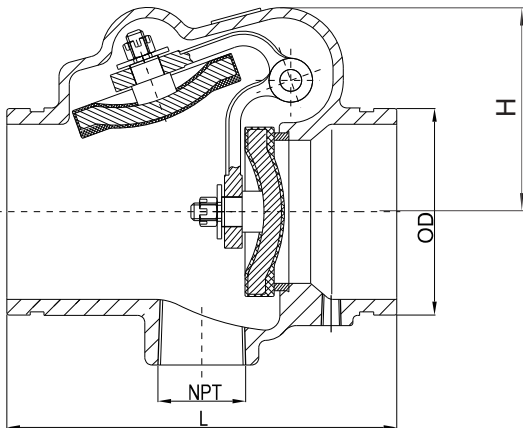

Materials List

Part Name	Material	Specification
Body	Ductile Iron	ASTM A536 65-45-12
Seat	Bronze	ASTM B62 C83600
Clapper	Q235+SS304+EPDM	
Clapper Arm	Stainless Steel	ASTM A351 CF8
Washer	Stainless Steel	AISI 304
Hexagonal Slot Thin Nut	Stainless Steel	AISI 304
Split Pin	Stainless Steel	AISI 304

Dimensions(mm/inch)

SIZE	mm	50	65	80	100	125	150	200	250	300
	inch	2	2½	3	4	5	6	8	10	12
L	mm	169	203	213	245	267	292	356	432	495
OD	mm	60.3	73.0/76.1	88.9	114.3	139.7/141.3	165.1/168.3	219.1	273	323.85
NPT	inch	1	1¼	1¼	2	2	2	2	2	2
H	mm	79.3	85.3	93	103	121	142	233	274	306

Note: Subject to change without prior notice due to products optimization.

Swing Check Valve

Resilient Seated Grooved Ends Riser (Shotgun)

Fig. 58GGP-365



Valve Standard

Fusion bonded coating comply with AWWA C550

Features

- Can be installed horizontally or vertically (with upward flow)
- Convenient to install and maintain
- Low pressure drop

Working pressure

365PSI

Working Temperature

0°C to 80°C

Connection Ends

AWWA C 606 / GB/T 8260 / VDS2100

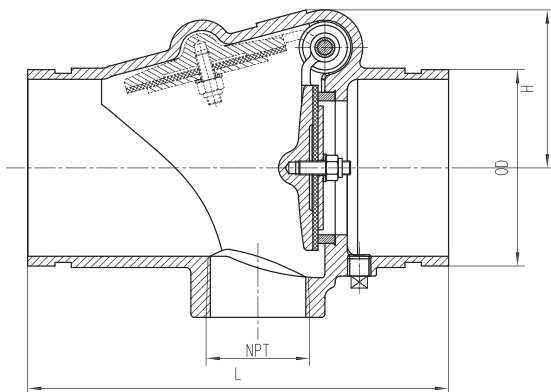

Materials List

Part Name	Material	Specification
Body	Ductile Iron	ASTM A536 65-45-12
Clapper	Ductile Iron	ASTM A536 65-45-12
Seat	Bronze	ASTM C83600
Disc Sealing Ring	EPDM	
Shaft	Stainless Steel	AISI 304
Pressing Plate	Stainless Steel	AISI 304

Dimensions(mm/inch)

SIZE	mm	50	65	80	100	125	150	200	250	300
	inch	2	2½	3	4	5	6	8	10	12
L	mm	169	203	213	245	267	292	356	432	495
OD	mm	60.3	73.0/76.1	88.9	114.3	139.7/141.3	168.3	219.1	273	323.9
NPT	inch	1	1¼	1¼	2	2	2	2	2	2
H	mm	79.3	85.3	93	103	121	142	233	274	306

Note: Subject to change without prior notice due to products optimization.

Check Valve

Resilient Seated Wafer Ends

Fig. 50W -300
50W-250
50W-200
50W-175

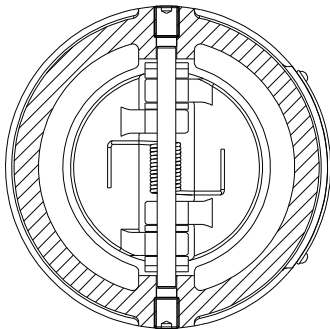
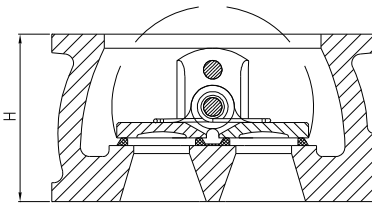

Valve Standard
Conforms to API 594

Working Pressure
175 PSI / 200PSI / 250PSI / 300PSI

Working Temperature
-20°C to 110°C

Flanged Ends
ASME B16.1 Class125
BS EN 1092-2 PN10/16
JISB2239 10K (Only for DN50-DN80/2"-3")
AS2129 TableD/TableE (Only for DN100-DN300/4"-12")

Materials List

Part	Material	ASTM Spec.
Body	Ductile Iron	A536 65-45-12
	Aluminum Bronze	B584 C95400
Disc	Stainless Steel	A351 CF8
	Stainless Steel	A351 CF8M
Stem	Stainless Steel	AISI 304
	Stainless Steel	AISI 316
Seat-Ring	EPDM	Commercial
Spring	Stainless Steel	AISI 304
	Stainless Steel	AISI 316

Note:
Lifting ring for DN200 (8") and above

Dimensions(mm/inch)

SIZE	mm	50	65	80	100	125	150	200	250	300
	inch	2	2½	3	4	5	6	8	10	12
H	mm	54	60	67	67	83	95	127	140	181
	inch	2.13	2.36	2.64	2.64	3.27	3.74	5.00	5.51	7.13

Note: Subject to change without prior notice due to products optimization.

Check Valve

Pressure-Temperature Chart

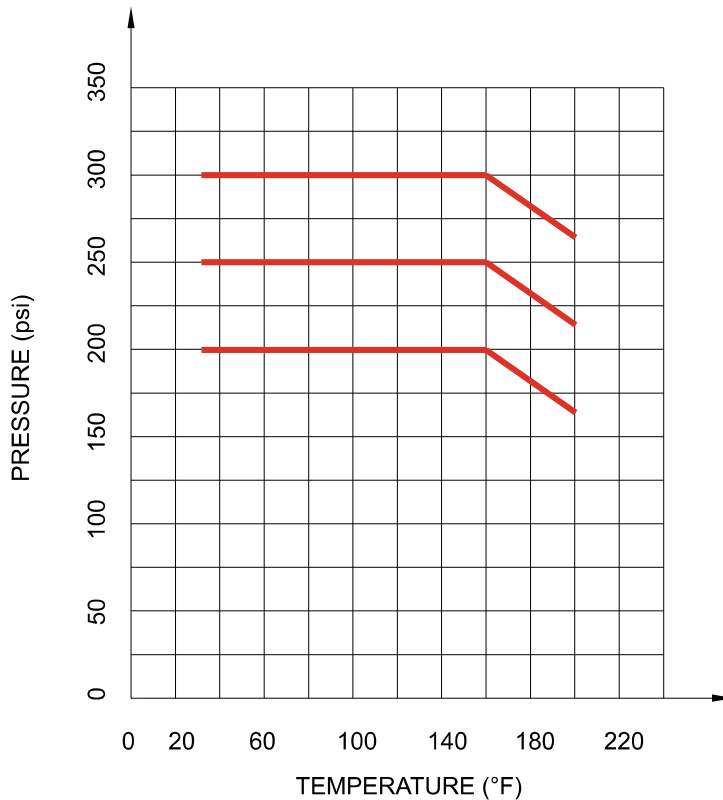
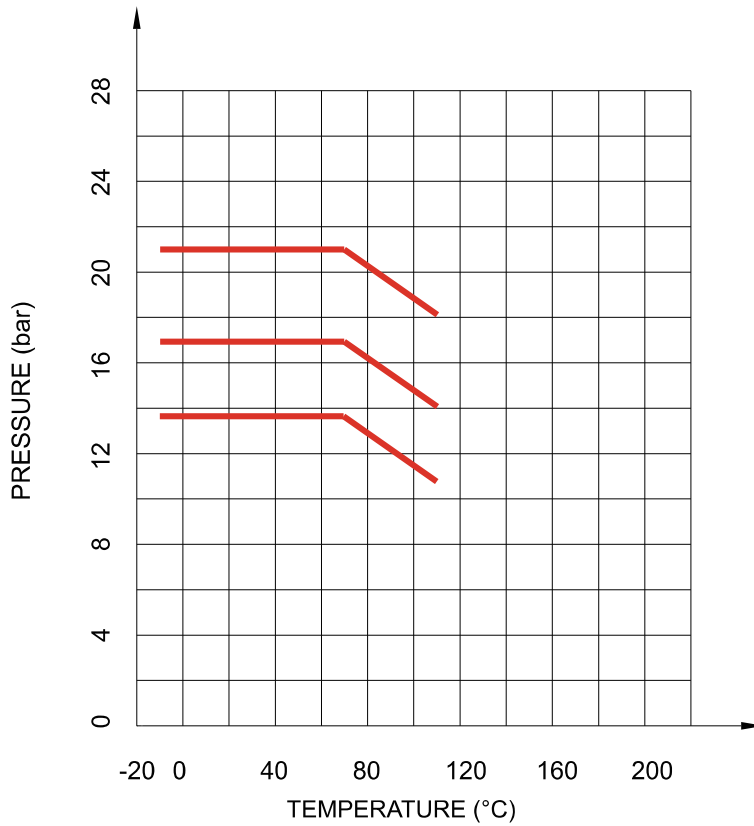

Note: Subject to change without prior notice due to products optimization.

Y Strainer

Flange-Flange Ends

Fig. 70FF-300
70FF-250
70FF-200



Valve Standard

Fusion bonded coating comply with AWWA C550

Working pressure

200PSI / 250PSI / 300PSI

Working Temperature

-10°C to 120°C

Flanged Ends

ANSI B16.1CLASS125/B16.42 CLASS150/B16.1CLASS250
EN1092-2 PN10/PN16/PN25
BS10 Table D/Table E

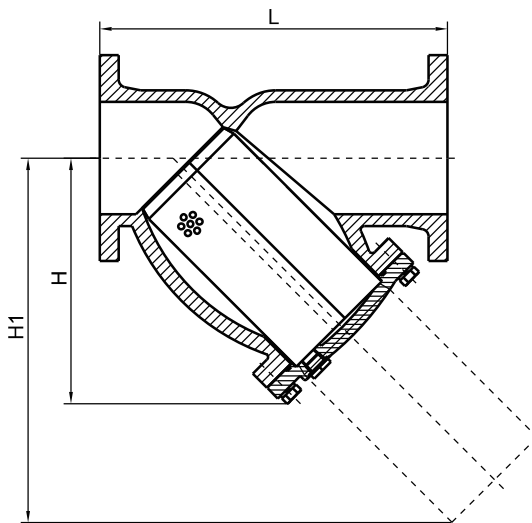

PLUG 3/4"

Materials List

Component	Material	Specification
Body	Ductile Iron	A536 65-45-12
Cover	Ductile Iron	A536 65-45-12
Screen	Stainless Steel	AISI 304
Gasket	EPDM	
Plug	Carbon Steel	

Dimensions(mm/inch)

SIZE	mm	50	65	80	100	125	150	200	250	300
	inch	2	2½	3	4	5	6	8	10	12
L	mm	203	254	260	308	398	472	550	654	762
	inch	7.99	10	10.24	12.13	15.67	18.58	21.65	25.75	30
H	mm	132	158	175	202	290	334	391	460	590
	inch	5.20	6.22	6.89	7.99	11.42	13.15	15.39	18.11	23.23
H1	mm	195	240	270	320	425	495	570	700	840
	inch	7.68	9.45	10.63	12.60	16.73	19.49	22.44	27.56	33.07

Note: Subject to change without prior notice due to products optimization.

Y Strainer

Flange-Groove Ends

Fig. 70FG-300
70FG-250
70FG-200



Valve Standard

Fusion bonded coating comply with AWWA C550

Working pressure

200PSI / 250PSI / 300PSI

Working Temperature

-10°C to 120°C

Flanged Ends

ANSI B16.1 CLASS125/B16.42 CLASS150/B16.1 CLASS250
EN1092-2 PN10/PN16/PN25
BS10 Table D/Table E
AWWA C 606
VDS2100

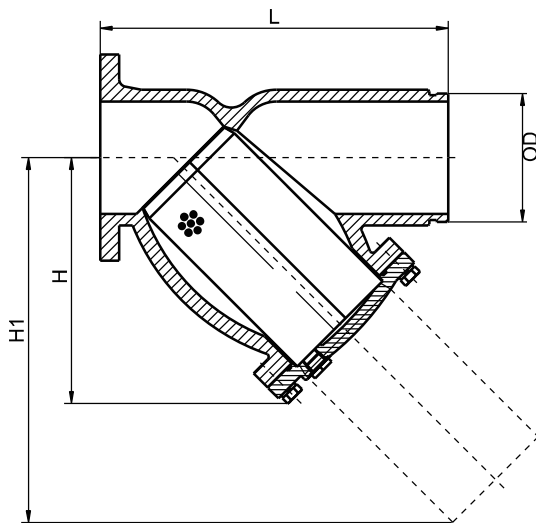

PLUG 3/4"

Dimensions(mm/inch)

SIZE	mm	50	65	80	100	125	150	200	250	300
	inch	2	2½	3	4	5	6	8	10	12
L	mm	203	254	260	308	398	472	550	654	762
	inch	8	10	10.24	12.13	15.67	18.58	21.65	25.75	30
H	mm	130	158	175	202	290	334	391	460	590
	inch	5.12	6.22	6.89	7.95	11.42	13.15	15.39	18.11	23.23
H1	mm	195	240	270	320	425	495	570	700	840
	inch	7.68	9.45	10.63	12.60	16.73	19.49	22.44	27.56	33.07
OD	mm	60.3	73.0/76.1	88.9	114.3	139.7/141.3	165.1/168.3	219.1	273	323.9
	inch	2.37	2.87/3	3.50	4.5	5.5/5.56	6.5/6.63	8.63	10.75	12.75

Materials List

Component	Material	Specification
Body	Ductile Iron	A536 65-45-12
Cover	Ductile Iron	A536 65-45-12
Screen	Stainless Steel	AISI 304
Gasket	EPDM	
Plug	Carbon Steel	

Note: Subject to change without prior notice due to products optimization.

Y Strainer

Groove-Groove Ends

Fig. 70GG-300
70GG-250
70GG-200



Valve Standard

Fusion bonded coating comply with AWWA C550

Working pressure

200PSI / 250PSI / 300PSI

Working Temperature

-10°C to 120°C

Flanged Ends

AWWA C 606
VDS2100

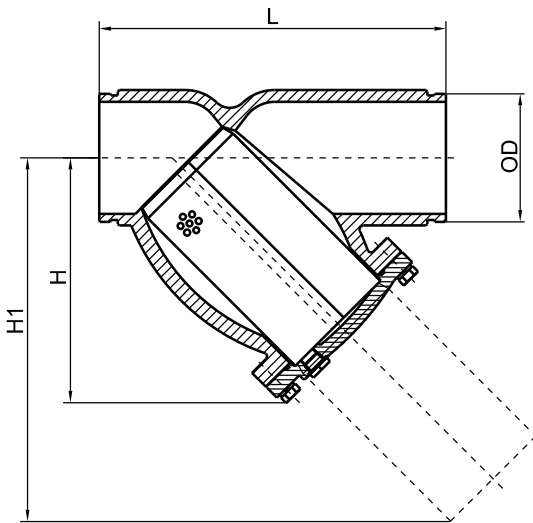

PLUG 3/4"

Materials List

Component	Material	Specification
Body	Ductile Iron	A536 65-45-12
Cover	Ductile Iron	A536 65-45-12
Screen	Stainless Steel	AISI 304
Gasket	EPDM	
Plug	Carbon Steel	

Dimensions(mm/inch)

SIZE	mm	50	65	80	100	125	150	200	250	300
	inch	2	2½	3	4	5	6	8	10	12
L	mm	230	254	272.4	308	398	472	550	654	762
	inch	9.06	10	10.71	12.13	15.67	18.58	21.65	25.75	30
H	mm	130	158	175	202	290	334	391	460	590
	inch	5.12	6.22	6.89	8	11.42	13.15	15.39	18.11	23.23
H1	mm	195	240	270	320	425	495	570	700	840
	inch	7.68	9.45	10.63	12.60	16.73	19.49	22.44	27.56	33.07
OD	mm	60.3	73.0/76.1	88.9	114.3	139.7/141.3	165.1/168.3	219.1	273	323.9
	inch	2.37	2.87/3	3.50	4.5	5.5/5.56	6.5/6.63	8.63	10.75	12.75

Note: Subject to change without prior notice due to products optimization.

Y Strainer

Pressure-Temperature Chart

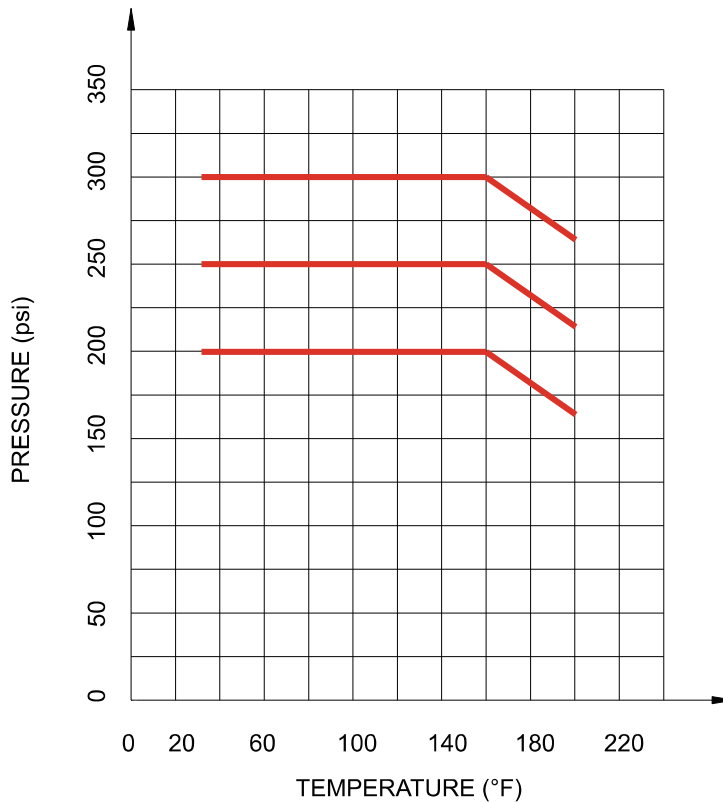
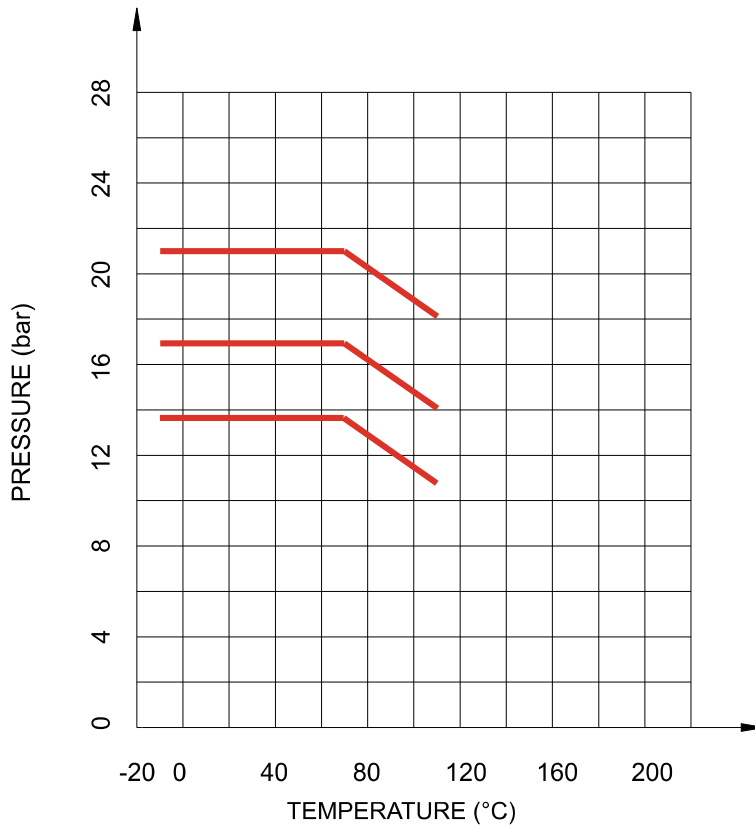

Note: Subject to change without prior notice due to products optimization.

Butterfly Valve

Wafer Butterfly Valve With Signal Gear Box

Fig.25W-300
25W-250
25W-200

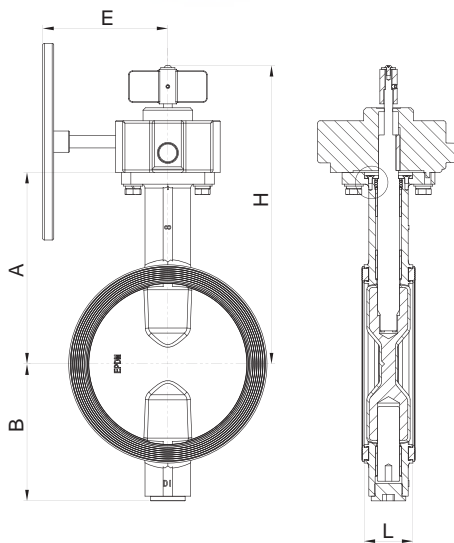

Valve Standard

Fusion bonded coating comply with FM1112, UL1091

Face-to-face Standard

ISO5752

Test Standard

FM1112, UL1091

Working pressure

200PSI / 250PSI / 300PSI

Working Temperature

-10°C to 120°C

Flanged Ends

BS EN1092-2 / ASME B16.42 / Class150

Materials List

Component	Material	Specification
Body	Ductile Iron	ASTM A536
Disc	Ductile Iron EPDM Coated	ASTM A536+EPDM
Upper&Lower Stems	Stainless Steel	AISI 410
O-Ring	EPDM	
Bushing	Bronze	ASTM B150M C63000
Gland	Galvanized Carbon Steel Surface Passivation	
Washer	Galvanized Carbon Steel Surface Passivation	
Plug	Galvanized Carbon Steel Surface Passivation	
Gear Box Housing	Ductile Iron	ASTM A536
Gear Box Fasteners	Galvanized Carbon Steel Surface Passivation	

Dimensions(mm/inch)

SIZE	mm	50	65	80	100	125	150	200	250	300
	inch	2	2½	3	4	5	6	8	10	12
A		140.5	152.5	157.5	176	191	202.5	243.5	273	311
B		77	80	87	108	132	144	174	208	261
L		43	46	46	52	56	56	62	68	78
E		110	110	110	110	133	133	187	187	187
H		262.4	274.5	279.5	298	313.5	330	379	409	465

Factory installed UL listed double Tamper Switches For indoor and Outdoor Use.

Note: Subject to change without prior notice due to products optimization.

Butterfly Valve

Lugged Butterfly Valve With Signal Gear Box

Fig.25L-200
25L-250
25L-300

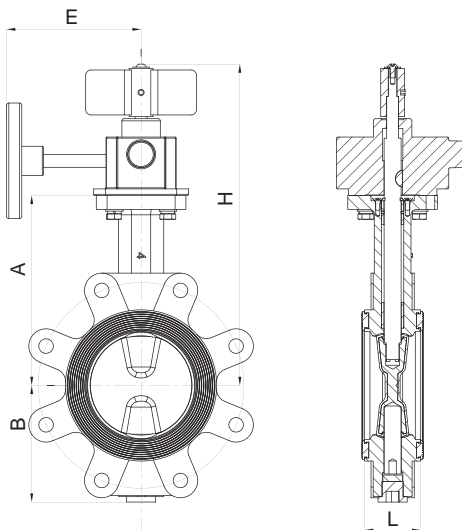
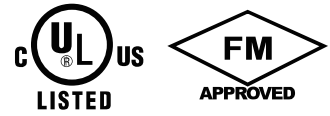

Valve Standard

Fusion bonded coating comply with FM1112,UL1091

Face-to-face Standard

ISO5752

Test Standard

FM1112,UL1091

Working pressure

200PSI / 250PSI / 300PSI

Working Temperature

-10°C to 120°C

Flanged Ends

BS EN1092-2 / ASME B16.42 / Class150

Materials List

Component	Material	Specification
Body	Ductile Iron	ASTM A536
Disc	Ductile Iron EPDM Coated	ASTM A536+EPDM
Upper&Lower Stems	Stainless Steel	AISI 410
O-Ring	EPDM	
Bushing	Bronze	ASTM B150M C63000
Gland	Galvanized Carbon Steel Surface Passivation	
Washer	Galvanized Carbon Steel Surface Passivation	
Plug	Galvanized Carbon Steel Surface Passivation	
Gear Box Housing	Ductile Iron	ASTM A536
Gear Box Fasteners	Galvanized Carbon Steel Surface Passivation	

Dimensions(mm/inch)

SIZE	mm	50	65	80	100	125	150	200	250	300
	inch	2	2½	3	4	5	6	8	10	12
A	140.5	152.5	157.5	176	191	202.5	243.5	273	311	
B	77	80	87	108	132	144	174	208	261	
L	43	46	46	52	56	56	62	68	78	
E	110	110	110	110	133	133	187	187	187	
H	262.4	274.5	279.5	298	313.5	330	379	409	465	

Switches For indoor and Outdoor Use.

Note: Subject to change without prior notice due to products optimization.

Butterfly Valve

Grooved Butterfly Valve With Signal Gear Box

Fig. 25GG-200
25GG-250
25GG-300

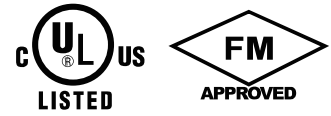

Valve Standard

Fusion bonded coating comply with FM1112,UL1091

Face-to-face Standard

MSS-SP67 Long

Test Standard

FM1112,UL1091

Working pressure

200PSI / 250PSI / 300PSI

Working Temperature

-10°C to 120°C

Flanged Ends

AWWA C606 / VDS 2100

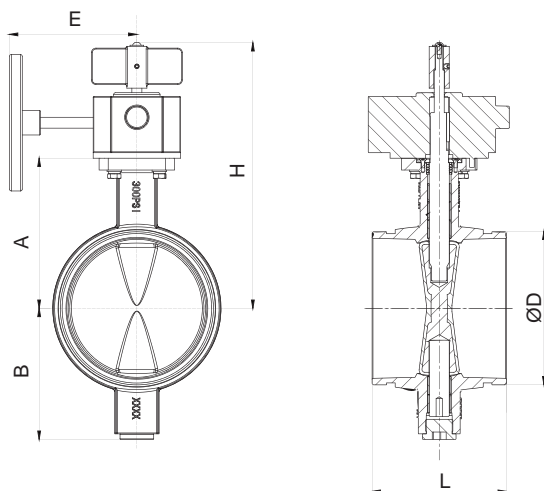

Materials List

Component	Material	Specification
Body	Ductile Iron	ASTM A536
Disc	Ductile Iron EPDM Coated	ASTM A536+EPDM
Upper&Lower Stems	Stainless Steel	AISI 410
O-Ring	EPDM	
Bushing	Bronze	ASTM B150M C63000
Gland	Galvanized Carbon Steel Surface Passivation	
Washer	Galvanized Carbon Steel Surface Passivation	
Plug	Galvanized Carbon Steel Surface Passivation	
Gear Box Housing	Ductile Iron	ASTM A536
Gear Box Fasteners	Galvanized Carbon Steel Surface Passivation	

Dimensions(mm/inch)

SIZE	mm	50	65	80	100	125	150	200	250	300
	inch	2	2½	3	4	5	6	8	10	12
A	95	98	105	135	148	165	204	245	277.5	
B	77	80	87	108	132	144	173	208	261	
L	84.5	98	98	116	149	147.6	134	160	165	
E	110	110	110	110	133	133	187	187	187	
H	217	216	227	256	275	292	339	380	426.5	
ØD	60.3	73/76.1	88.9	114.3	139.7/141.3	165.1/168.3	219.1	273	323.85	

Factory installed UL listed double Tamper Switches For indoor and Outdoor Use.

Note: Subject to change without prior notice due to products optimization.

Butterfly Valve

Resilient Seated Grooved Ends

Fig.20GG (Ductile Iron Body)
22G (Bronze Body)



Coating Standard

Fusion bonded coating comply with AWWA C550

Working pressure

175PSI

Working Temperature

-20°C to 110°C

Flanged Ends

AWWA C606

Materials List

Part	Material	Specification
Body (20GG)	Ductile Iron	ASTM A536 65-45-12
Body (22G)	Bronze	ASTM B62 C83600
Disc	Steel+EPDM	ASTM 1045+EPDM
Upper Shaft	Stainless Steel	SS630
Lower Shaft	Stainless Steel	SS630
O-Ring	EPDM	
Gasket	Stainless Steel	AISI 304

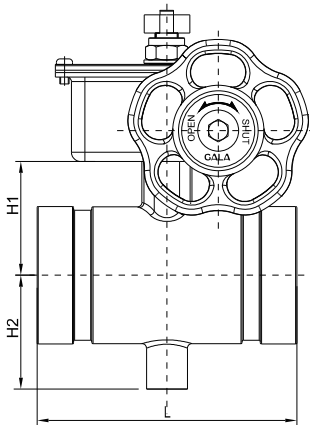

Dimensions(mm/inch)

SIZE	mm	inch
	50	2
	65	2½
H1	50	1.97
	55.5	2.19
H2	50	1.97
	55.5	2.19
L	114	4.49
	114	4.49

Factory installed UL listed double Tamper Switches For indoor and Outdoor Use.

Note: Subject to change without prior notice due to products optimization.

Butterfly Valve

Resilient Seated Screwed Ends

Fig.20T (Ductile Iron Body)
22T (Bronze Body)



Coating Standard

Fusion bonded coating comply with AWWA C550

Working pressure

175PSI

Working Temperature

-20°C to 110°C

Flanged Ends

ASME B1.20.3 NPT/EN10226-1 Rp

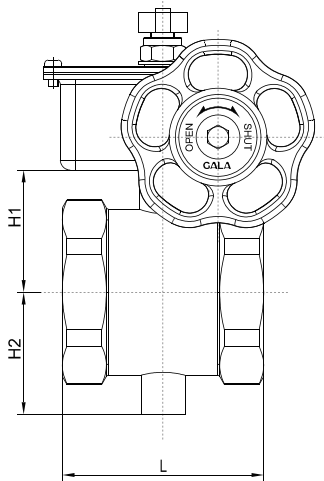

Materials List

Part	Material	Specification
Body (20T)	Ductile Iron	ASTM A536 65-45-12
Body (22T)	Bronze	ASTM B62 C83600
Disc	Steel+EPDM	ASTM 1045+EPDM
Upper Shaft	Stainless Steel	SS630
Lower Shaft	Stainless Steel	SS630
O-Ring	EPDM	
Gasket	Stainless Steel	AISI 304

Dimensions(mm/inch)

SIZE	mm	25	32	40	50	65
	inch	1	1¼	1½	2	2½
H1	mm	37	42	44	50	55.5
	inch	1.46	1.65	1.73	1.97	2.19
H2	mm	29	35	41	50	55.5
	inch	1.14	1.38	1.61	1.97	2.19
L	mm	54	67	73	82.4	104
	inch	2.13	2.64	2.87	3.24	4.09

Factory installed UL listed double Tamper Switches For indoor and Outdoor Use.

Note: Subject to change without prior notice due to products optimization.

Air Release Valve

Screwed

Fig. 9712

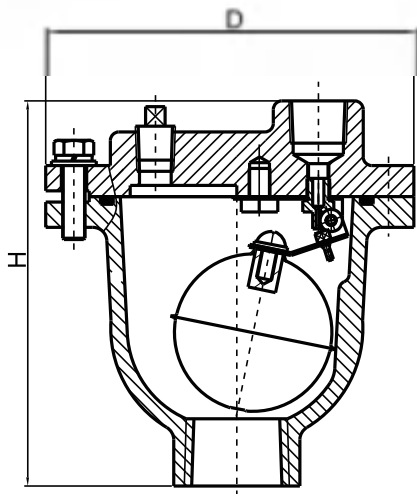

Valve Standard

Fusion bonded coating comply with AWWA C550

Working pressure

200PSI

Working Temperature

-10°C to 120°C

Connection Ends

NPT/BSPT/BSPP

Materials List

Part	Material	ASTM Spec.
Body	Ductile Iron	A536 65-45-12
Cover	Ductile Iron	A536 65-45-12
Level	Stainless Steel	AISI 304
Seat Ring	Stainless Steel	AISI 304
Float	Stainless Steel	AISI 304
Float Arm	Stainless Steel	AISI 304
Orifice Button	Viton	Commercial

Dimensions

DN		Inlet	Outle	Orifice	D	H
mm	inch					
15	1/2	15	15	1.6	125	137
20	3/4	20	15	1.6	125	137
25	1	25	15	1.6	125	137

Note: Subject to change without prior notice due to products optimization.

Dry Barrel Fire Hydrant

Fig. 1510



Technical Specification

Design Standard	FM 1510/UL 246/AWWA C502
Coating Standard	AWWA C550
Nozzle Thread Standard	NFPA 1963
Hose Nozzle	2-1/2"-Two
Pumper Nozzle	4" or 4-1/2"-One
Mechanical Jiont	Size: 6" ANSI/AWWA C111/A21.11 ANSI/AWWA C153/A21.53
Flange End	Size: 6" ANSI Class 125 / 150 BS EN1092-2 PN10 / 16
Working Pressure	250PSI

Part name	Material
Operating Nut	C84400
Dust Ring	EPDM
Lock Nut	CF8
Antifricition Mat	C63000/PTFE
Plug	SS304
Cover	65-45-12
Uper Hydrant Body	6-4-12
Top Shaft	SS420/45
Gland	SS304
Fire Engine Nozzle Cap	65-45-12
Fire Engine Nozzle Gasket	EPDM
Fire Engine Nozzle	C84400
Steel Wire Rope	SS304 Plastic Coated
O-Ring	EPDM
Coupling	SS420/45
Lower Hydrant Body	65-45-12
Safety Flange	65-45-12
Under Shaft	SS420/45
Drain Valve Cover	65-45-12
MJ Elbow Body	65-45-12
Hexagon Head Blots	SS304
Flat Washer	SS304
Spring Washer	SS304
Hexagonal Nut	SS304
Drain Valve Cover Seal	EPDM
Pin	SS304
Cotter Pin	SS304
Uper Fire Hydrant Body Seal	EPDM
Hexagon Socket Head Screws	SS304
Hose Nozzle Cap	65-45-12
Hose Nozzle Gasket	EPDM
Hose Nozzle	C84400
Hexagon Socket Set Screws	SS304
Drain Valve Cap	C84400+EPDM
Spring	SS304
Seat	C84400
Tablet	65-45-12
Disc Sealing Ring	EPDM
Disc	65-45-12
Nut Press Ring	65-45-12+EPDM

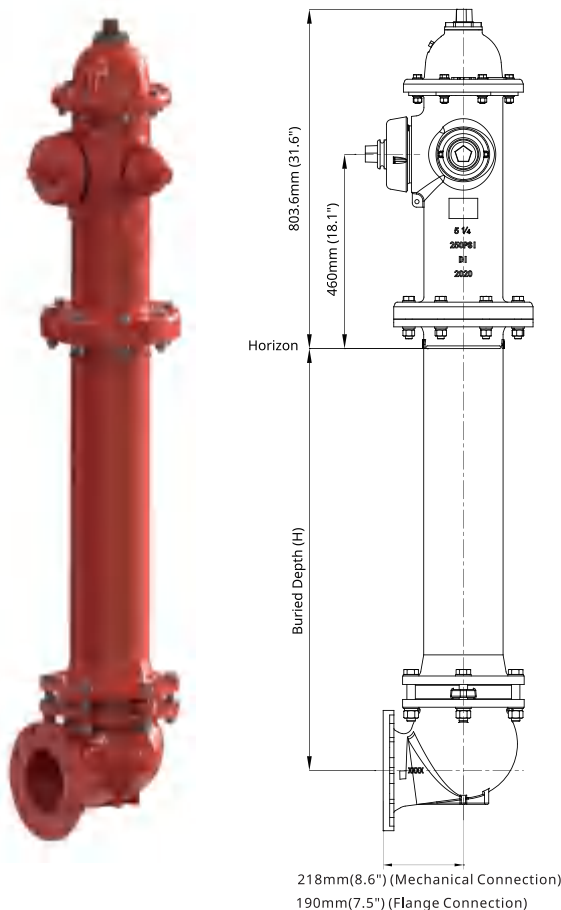

Buried Depth (H)

inch	1'	2'	3'	3'-6"	4'-0"	4'-6"	5'-0"	5'-6"	6'-0"	6'-6"	7'-0"
mm	326	543	848	1001	1153	1306	1458	1611	1763	1916	2068

Note: Subject to change without prior notice due to products optimization.

Wet Barrel Fire Hydrant

Fig.1511

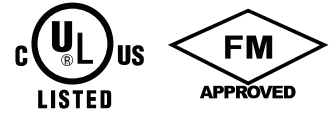

Technical Specification

Design Standard	FM 1511/UL 246/AWWA C503
Coating Standard	AWWA C550
Nozzle Standard	NFPA 1963
Hose Nozzle	2.5" *2
Pumper Nozzle	4.5" or 4" *1
Monitor Flange	Size: 4"-ANSI Class125/150
Inlet Flange Connection	Size: 6"-ANSI Class125/150 BS EN 1092-2 PN10/16
Working Pressure	250PSI

Part Name	Material
Hydrant Body	65-45-12
Steel Wire Rope	SS304 Plastic coated
O-Ring	EPDM
FireEngineNozzle Cap	65-45-12
FireEngine Nozzle	C84400
FireEngi neNozzle Gasket	EPDM
4.5" Gland	CF8
Inner Six Angle Flat End Set Screw	A2
4.5" Disc Sealing Ring	EPDM
4.5" Disc	CF8
Shaft	SS304/SS420
Fixed Nut	CF8
Inner Six Angle Cylindrical Head Screw	A2-70
4.5" Shaft Nut	C84400
Operating Nut	CF8
Hexagonal Nut	A2-70
Hose Nozzle Cap	65-45-12
Hose Nozzle	C84400
Hose Nozzle Gasket	EPDM
2.5" Gland	CF8
2.5" Disc Sealing Ring	EPDM
2.5" Disc	CF8
Shaft Stem Nut	C84400
Inner Six Angle Set Screw	Carbon Steel + Zn



2H1PM

2H1P

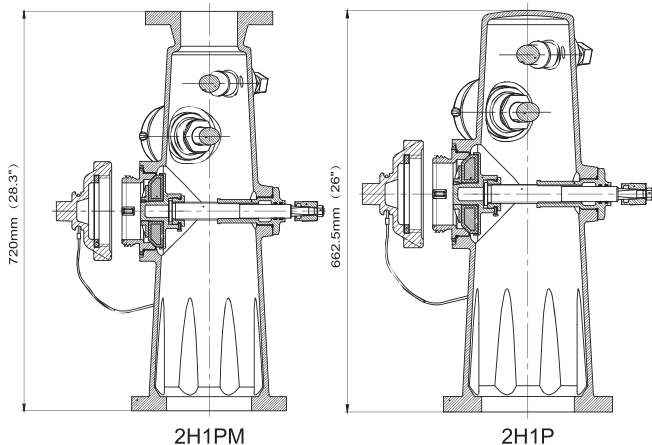

2H1PM

2H1P

Note: Subject to change without prior notice due to products optimization.

Coating

- 1.The Valve are with epoxy coating.
- 2.Red (RAL3002)/Yellow(RAL1003)

Wet Barrel Fire Hydrant

Fig.1511



Technical Specification

Design Standard	FM 1511/UL 246/AWWA C503
Coating Standard	AWWA C550
Nozzle Standard	NFPA 1963
Hose Nozzle	2.5" *2
Pumper Nozzle	4.5" or 4" *1
Monitor Flange	Size: 4"-ANSI Class125/150
Inlet Flange Connection	Size: 6"-ANSI Class125/150 BS EN 1092-2 PN10/16
Working Pressure	250PSI

Part Name	Material
Hydrant Body	65-45-12
Steel Wire Rope	SS304 Plastic coated
O-Ring	EPDM
FireEngineNozzle Cap	65-45-12
FireEngine Nozzle	C84400
FireEngi neNozzle Gasket	EPDM
4.5" Gland	CF8
Inner Six Angle Flat End Set Screw	A2
4.5" Disc Sealing Ring	EPDM
4.5" Disc	CF8
Shaft	SS304/SS420
Fixed Nut	CF8
Inner Six Angle Cylindrical Head Screw	A2-70
4.5" Shaft Nut	C84400
Operating Nut	CF8
Hexagonal Nut	A2-70
Hose Nozzle Cap	65-45-12
Hose Nozzle	C84400
Hose Nozzle Gasket	EPDM
2.5" Gland	CF8
2.5" Disc Sealing Ring	EPDM
2.5" Disc	CF8
Shaft Stem Nut	C84400
Inner Six Angle Set Screw	Carbon Steel + Zn



1H1PM

1H1P

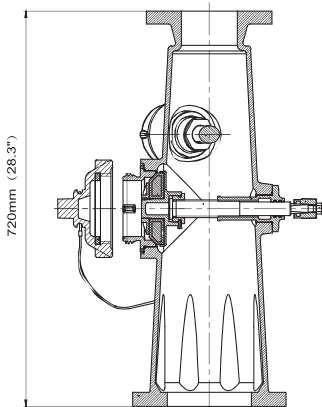

1H1PM

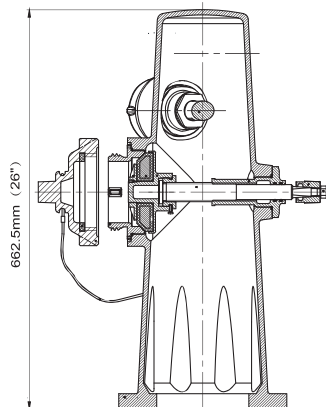

1H1P

Coating

- 1.The Valve are with epoxy coating.
- 2.Red (RAL3002)/Yellow(RAL1003)

Note: Subject to change without prior notice due to products optimization.

Wet Barrel Fire Hydrant

Fig. 1511



Technical Specification

Design Standard	FM 1511/UL 246/AWWA C503
Coating Standard	AWWA C550
Nozzle Standard	NFPA 1963
Hose Nozzle	2.5" *2
Montor Flange	Size:4"-ANSI Class 125/150
Inlet Flange Connection	Size:6"-ANSI Class 125/150 BS EN 1092-2PN10/16
Working Pressure	250PSI

Part Name	Material
Hydrant Body	65-45-12
Steel Wire Rope	SS304 Plastic coated
0-Ring	EPDM
Hose Nozzle Cap	65-45-12
Hose Nozzle	C84400
Hose Nozzle Gasket	EPDM
2.5" Gland	CF8
Inner Six Angle Flat End Set Screw	A2
2.5" Disc Sealing Ring	EPDM
2.5" Disc	CF8
Shaft	SS304/SS420
Fixed Nut	CF8
Inner Six Angle Cylindrical Head Screw	A2-70
Shaft Nut	C84400
Operating Nut	CF8
Hexagonal Nut	A2-70
Inner Six Angle Set Screw	Carbon Steel + Zn



2H0PM

2H0P

Coating

- 1.The Valve are with epoxy coating.
- 2.Red (RAL3002)/Yellow(RAL1003)

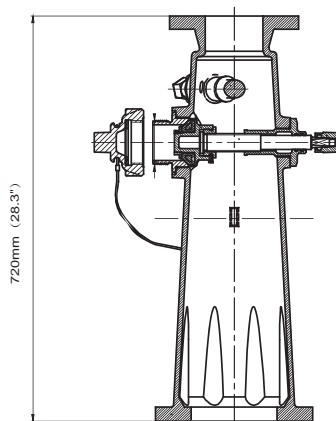

2H0PM

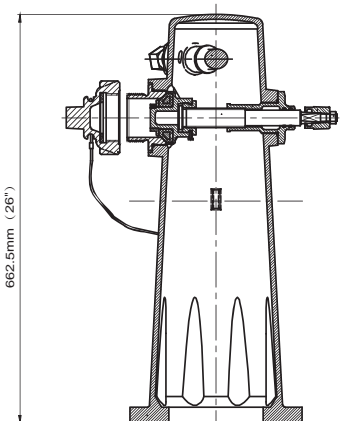

2H0P

Note: Subject to change without prior notice due to products optimization.

Water Flow Detector With Retard

Fig.1042-V



DESCRIPTION

The 1042-V is a vane type water flow detector for use on fire protection and wet sprinkler system. It is suitable for use with Schedule 10 through 40 steel pipe of 2" to 8", and can be installed in vertical or horizontal pipe. The detectors shall have a sensitivity in the range of 4 to 10 gallons per minute, and a service pressure up to 450psi. 1042-V will respond to waterflow in the specified direction after preset time delay that is adjustable on site.

FEATURES AND SPECIFICATIONS

- Two conduit opening of 1/2". One open; one knock-out type
- Sensitivity Range : 4 ... 10 usgpm
- Contact Rating : Two sets of SPDT (Form C) 10Amps (125 / 250 VAC) / 2Amps (24 VDC)
- Enclosure Rating : NEMA 4- suitable for indoor / outdoor
- Compatible Pipe: 2" to 8"
- Special tamper screws to prevent disassembly
- Maximum Surge : 5.5m/s
- Time delay adjustment via rotating dial
- Two sets Micro-switch, 100% synchronization
- Working pressure : Max. 31bar / 450psi
- Working temperature : 4.5°C ... 49°C

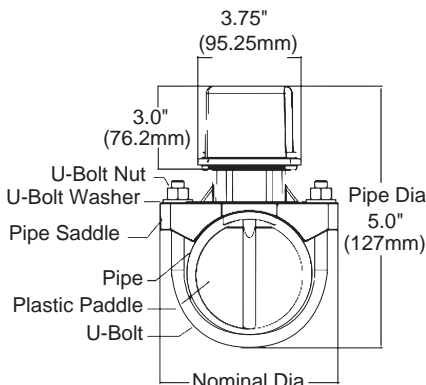

Nominal Dia 5.15" (130.8mm) for 2" ... 2½" (DN50 ... DN65)
 Nominal Dia 2.05" (52.1mm) for 3" ... 8" (DN80 ... DN200)

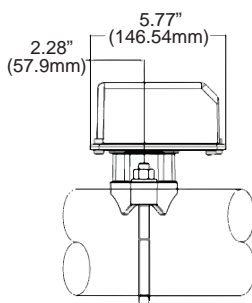

ORDERING MODEL AND SIZE

MODEL	PIPE SIZE	HOLE SIZE
1042-V-050	50mm (2")	31.8mm (1¼")
1042-V-065	65mm (2.5")	31.8mm (1¼")
1042-V-080	80mm (3")	50.8mm (2")
1042-V-100	100mm (4")	50.8mm (2")
1042-V-150	150mm (6")	50.8mm (2")
1042-V-200	200mm (8")	50.8mm (2")

Note: Subject to change without prior notice due to products optimization.

Water Flow Detector With Retard

Fig.1042-V



INSTALLATION GUIDE

The 1042-V water flow detector may be mounted on a horizontal or vertical pipe. On horizontal pipe, it should be installed on the top side of the pipe where they will be accessible. The detector should not be installed within 6" (150mm) of a fitting which changes the direction of the waterflow or within 24" (600mm) of a valve or drain.

Drain the system and drill a hole on the pipe. The 2" (50mm) and 2½" (65mm) detectors require a hole with a diameter of 1¼" +/- 0.08" (31.8mm +/- 2mm). All other sizes require a hole with a diameter of 2" +/- 0.08" (50.8mm +/- 2mm).

Clean the inside pipe of all growth or other material for a distance equal to the pipe diameter on either side of the hole.

Roll the vane so that it may be inserted into the hole; do not bend or crease it. Insert the vane with the arrow on the saddle points in the direction of the waterflow.

Do not leave cover off for an extended period of time.

Retard Adjustment : The delay can be adjusted by rotating the retard adjustment knob from 0~Max position (0~90 secs). Factory setting is position 2 (Delay time is approximate 30 seconds). The time delay should be set at the minimum required to prevent false alarms.

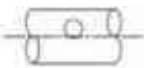
CAUTION	
Hole must be drilled perpendicular to the pipe and vertically centered.	
CORRECT	INCORRECT
	

ELECTRICAL CONNECTIONS AND TIME DELAY ADJUSTMENT

The 1042-V water flow detector have two switches, one can be used to operate a central station, proprietary or remote signaling unit, while the other contact is used to operate a local device or visual annunciator.

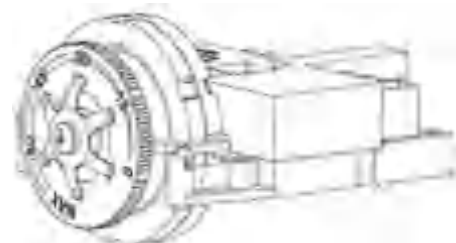

Note : Retard Structure can be set from "0" to "MAX" position, delay time can be set from 0~90 secs.

Note: Subject to change without prior notice due to products optimization.

Water Flow Detector With Retard

Fig.1042-T

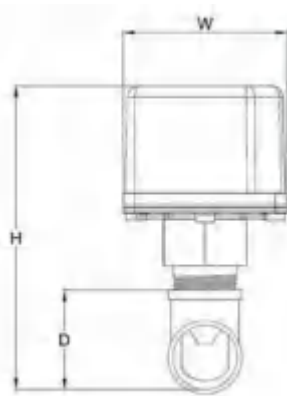
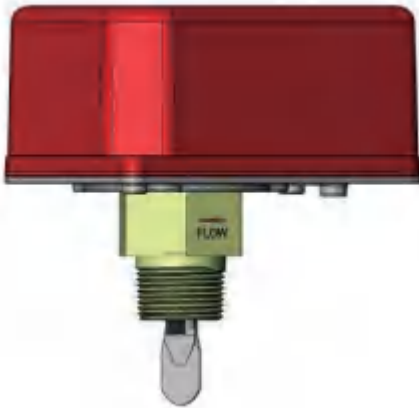

FEATURES

- FM Approved.
- Rating Working Pressure: FM-Max 450PSI (3.1MPa)
- Flow Sensitivity Range for Signal: 4-10GPM (15.0-37.5L/min)
- Maximum Surge: 18FPS (5.5m/s)
- Contact Ratings: Two sets of SPDT (Form C)
 - 10.1Amps at 125/250 VAC
 - 2.0Amps at 24 VDC
- Operating Temperature Range: 40° F to 120°F (4.5°C to 49°C)
- Enclosure Rating: NEMA 4- suitable for indoor/outdoor use
- Conduit Entrances: Two opening for 1/2" conduit
One open, one knock-out type
- Compatible Pipe: Fits 1", 1-1/4", 1-1/2" and 2" ferrous and brass threaded tees
- COVER Material: Aluminum Die-casting. Alternative Material Plastic

ENGINEERING SPECIFICATIONS

The 1042-T water flow detector shall be installed in a tee that has a 1 inch NPT side outlet include 1in.、 1-1/4 in.、 1-1/2 in. and 2in. as designated on the drawing and/or as specified herein. Water flow detectors shall mount on any clear pipe span of the appropriate nominal size, either a horizontal or vertical pipe. The detector shall respond to water flow in the specified direction after a preset time delay that is field adjustable. The retard structure shall be a sealed mechanical pneumatic unit with visual time delay adjustment.

INSTALLATION

The 1042-T water flow detector may be mounted on horizontal or vertical pipe. On horizontal pipe they should be installed on the top side of the pipe where they will be accessible. The devices should not be installed within 6" (150mm) of a fitting which changes the direction of the water flow or within 24" (600mm) of a valve or drain. Select the proper paddle for the pipe size and type of TEE used according to below table changing paddle refer to Fig.2. The unit has 1" NPT male thread for installation into a TEE. Refer to Fig.1 for proper TEE size and installation. Use no more than three wraps of Teflon tape.

Screw the device into the TEE fitting as shown in Fig.1. Care must be taken to properly orient the device for the direction of water flow. The vane must not rub the inside of the TEE or bind in any way. The stem should move freely when operated by hand.

Note: Subject to change without prior notice due to products optimization.

Water Flow Detector With Retard

Fig.1042-T



NOTE: Do not leave cover off for an extended period of time. Retard Adjustment: The delay can be adjusted by rotating the retard adjustment knob from 0~Max position (0~90secs). Factory setting is position 2 (Delay time is approximate 30 seconds). The time delay should be set at the minimum required to prevent false alarms.

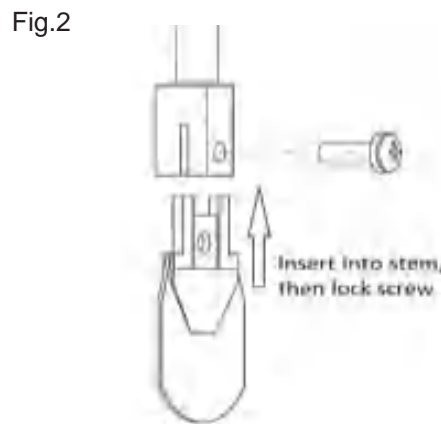
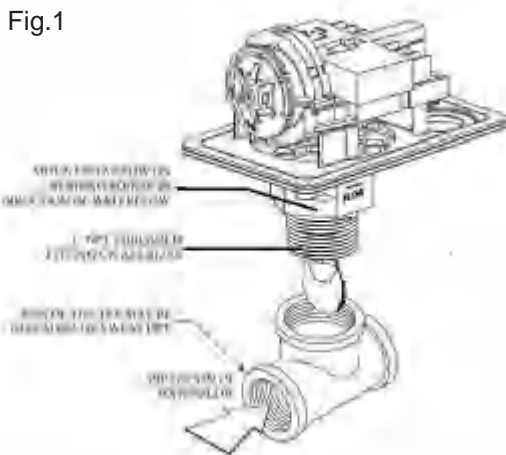

Field Typical Electrical Connections:

Notes:

The 1042-T water flow detector has two switches, one can be used to operate a central station, proprietary or remote signaling unit, while the other contact is used to operate a local device or visual annunciator.

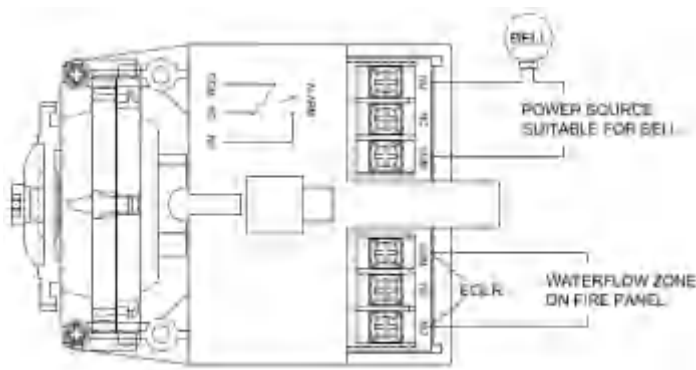

This additional pin hole would allow the wrench (coming with the device) to insert into it and temporarily stop the device from functioning causing false alarm during the maintenance. When the wrench is in there, it also prevents the red device cover to be removed.

Dimensions (mm, Inch)

SIZE	1"DN25	1-1/4"DN32	1-1/2"DN40	2"DN50
W	88.90/3.50	88.90/3.50	88.90/3.50	88.90/3.50
H	165.00/6.50	173.65/6.84	180.00/7.08	193.20/7.61
D (Depth)	54/2.12	62.5/2.46	69/2.71	82/3.22

Note: Subject to change without prior notice due to products optimization.

Brass Valve

Test and Drain

Fig.1601



Valve Standard

Positive positioning of handle for OFF TEST or DRAIN

- Only 2 threaded connections
- Large, integral sight glass on both sides
- 1/2"(nominal) test orifice
- K factor: 5.6

Working Pressure

300psi

Materials List

Part	Material	Specification
Body	Brass	C37700
Seat	PTFE	
Ball	Brass	C37700
Stem	Brass	C37700
O-Ring	NBR	
Lever	Stainless Steel	
Gland	Brass	C37700
Cap	Brass	C37700
Spring	Stainless Steel	A351 CF8
Washer	NBR	
Nut	Stainless Steel	

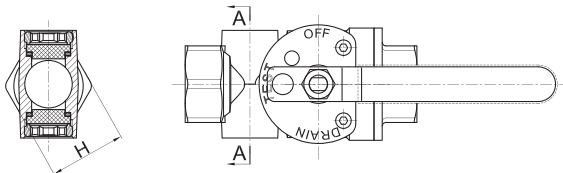
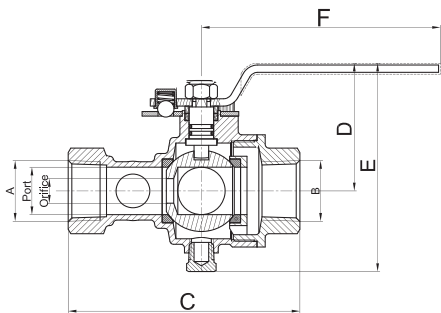

Dimensions(mm/inch)

A/B(Orifice)	Orifice	Port	A	B	C	D	H
1"	1/2"	1.024"	5"	2.76"	5.16"	4.5"	1.65"
1-1/4"	1/2"	1.024"	5"	2.76"	5.16"	4.5"	1.65"
1-1/2"	1/2"	1.575"	6.57"	3.5"	6.34"	5.8"	2.28"
2"	1/2"	1.575"	6.57"	3.5"	6.34"	5.8"	2.28"

Note: Subject to change without prior notice due to products optimization.

Brass Valve

Hose Valve

Fig.1615



Valve Standard

- Used with a fire hose rack assembly or as a fire dept outlet connection.
- FEMALE x MALE
FEMALE x MALE
GROOVE x MALE

Standard Equipment

- Outlet forge brass valve
Red hand wheel
- | | |
|---------------|---------------|
| 1-1/2 | 2-1/2 |
| FNPSH x MNPSH | FNPSH x MNPSH |
| FNPT x FNPT | FNPT x FNPT |
| FNPSH x FNPSH | FNPSH x FNPSH |
| | FNPT x MNYC |
| | GRV x MNH |
| | GRV x MNYC |
| | MNH x MNYC |

Working Pressure

300psi

Materials List

Part	Material	Specification
Body	Brass	ASTM B283 C37700
Seat Seal	EPDM	
Holder	Brass	ASTM B283 C37700
Stem	Brass	ASTM B283 C37700
O-Ring	EPDM	
Handle Wheel	Aluminium Alloy	ZL102
Gland	Brass	ASTM B283 C37700
Bonnet	Brass	ASTM B283 C37700
Set Screw	Stainless Steel	A351 CF8
Washer	Stainless Steel	A351 CF8
Nut	Brass	ASTM B283 C37700

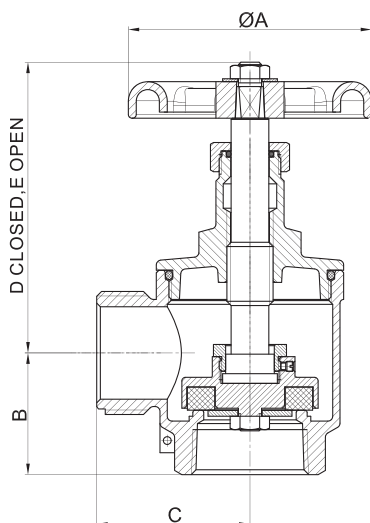

Dimensions(mm/inch)

Size	A	B	C	D	E
1½"x1½"	100	50	63	119	145
2½"x2½"	127	68	79	157	200

Note: Subject to change without prior notice due to products optimization.

Brass Valve

Pressure Reducing-Angle Valve

Fig.1620



Valve Standard

- Pressure Reducing Device Angle Valve 175 Lb.
- Rated adjustable restriction of residual pressure up to 175 Lb.
- Locking pin device restricts full opening of valve by untrained personnel, pin may be removed by firefighters to allow full opening of valve.
- FEMALE x MALE
FEMALE x FEMALE

Standard Equipment

Outlet forge brass valve

Red hand wheel

1-1/2

FEMALE NPT x MALE NH

FEMALE NPT x FEMALE NPT

2-1/2

FEMALE NPT x MALE NH

FEMALE NPT x FEMALE NPT

Rc x M78 x 2

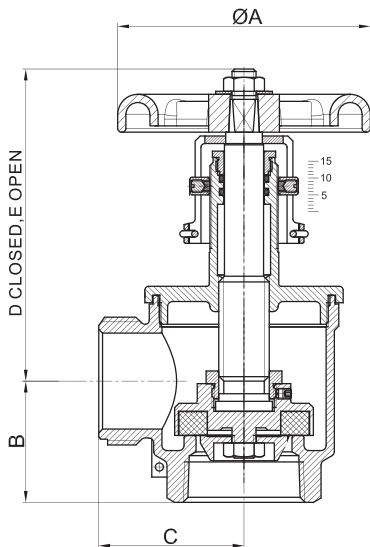

Working Pressure

FM 175psi/300psi

UL 175psi

Materials List

Part	Material	Specification
Body	Brass	ASTM B283 C37700
Seat Seal	EPDM	
Holder	Brass	ASTM B283 C37700
Stem	Brass	ASTM B283 C37700
O-Ring	EPDM	
Handle Wheel	Aluminium Alloy	ZL102
Gland	Brass	ASTM B283 C37700
Bonnet	Brass	ASTM B283 C37700
Set Screw	Stainless Steel	A351 CF8
Washer	Polyamide	PA6
Nut	Brass	ASTM B283 C37700

Dimensions(mm/inch)

Size	A	B	C	D	E
1½"x1½"	100	48	58	123	145
2½"x2½"	127	67	77	165	206

Note : Subject to change without prior notice due to products optimization.

Brass Valve

Ball Valve

Fig.1640



Valve Standard

- Brass ball valve (Full port)
- Steel handle with plastic handle
- FM/UL Certificated Size: 1/4" 3/8" 1/2" 3/4" 1" 1-1/4" 1-1/2" 2"

Working Pressure

FM 300psi
UL 600psi

Materials List

Part	Material	Specification
Body	Brass	ASTM B283 C37700
Seat Retainer	Brass	ASTM B283 C37700
Seat	PTFE	
Ball	Brass	ASTM B283 C37700
Stem	Brass	ASTM B283 C37700
O-Ring	Rubber	
Lever	Stainless Steel	A351 CF8

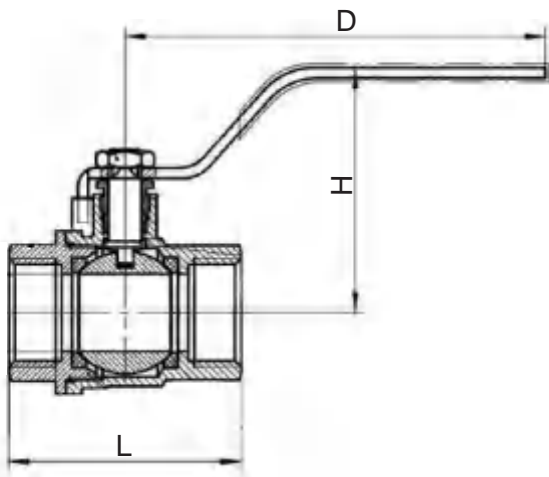

Dimensions(mm/inch)

Size	mm	6	10	15	20	25	32	40	50	65	80	100
	inch	1/4	3/8	1/2	3/4	1	1-1/4	1-1/2	2	2-1/2	3	4
D		89	89	89	104	117.5	117.5	145	145	232	232	232
H		46	46	51.5	61	63.5	70	94	102	115	126	141
L		44	44	57	63	75.5	86.5	94.2	108	136	160.5	185

Note: Subject to change without prior notice due to products optimization.

Brass Valve

Fire Department Connections

Fig.1650



Features

- The brass seat is integrated with brass body
- 2.5" swivels are pin lug design for easy operation
- Compatible with local fire service requirements
- Breakable plastic plug to prevent debris from being accidentally introduced into the water way
- Straightway Inlet x Outlet: NSTxNPT
- K factor: 5.6

Description

GALA FM Approved and UL listed Fire Department Connections are designed and manufactured in accordance with UL 405 - Standard for Fire Department Connections. We have two models, one is a straight type and a 90° type which casted from solid brass alloy to extend its service life. Only straight type have FM/UL Approved. Accessories haven't FM/UL Approved.

Optional Accessories



Wall Plates

The wall plates are constructed of corrosion resistant aluminium alloy with marking "AUTO SPKR" and "FIRE DEPT CONNECTION"



Caps

The breakaway caps are supplied in heavy duty plastic or cast aluminium alloy for the protection of 2½ inlets.

Working Pressure

300psi

Installation

The Fire Department Connection is provided with standard taper pipe threads which conforms to ANSI B2.1 and pin lug hose thread swivels for coupling hoses. Prior to installation, Apply pipe joint compound or PTFE tape on male threads, then, tighten it one full turn after tightening with hand, and make sure Connections are aligned accordance to the requirement.

Dimensions(mm/inch)

Size	Type	Working Pressure	Test Pressure	Installation	Swivel thread
4x2.5x2.5	Straight	300 psi	600 psi	4"F.NPT	2-F.NNH(NST)
4x2.5x2.5	90°	300 psi	600 psi	4"F.NPT	2-F.NNH(NST)

Not e: Subject to change without prior notice due to products optimization.



GALA HQ
GALA RS INC

8605 Santa Monica Blvd 30327
West Hollywood, CA 90069
Tel: 1-713-562-8136
Web: www.gala-valves.com

GALA CHINA

Tianjin Galaxy Valve Co., Ltd

No.49, Guanghui Road, Beizhakou Town,
Jinnan District, Tianjin, China
Tel: +86-22-28750815
Web: www.galaxyvalves.com

GALA THAILAND

Galaxy Valves(Thailand) Co., Ltd

209/21 Moo 2, Tombon Phraeksamai,
Amphoe Mueang Samutprakan,
Changwat Samutprakan, Thailand
Tel: +66-2-1380469
Web: www.galaxyvalves.th

GALA MIDDLE EAST

Gala International Fze

LB18 2101-2103, Jafza View 18,
Jafa, Dubai, UAE
Tel: 971-488-56516
Web: www.gala-valves.com

GALA RUSSIA

LLC Aquaflow Controls

Москва, Каширское шоссе. Зк2с12, офис 302
Web: www.gala-valves.com/ru/
Tel: +7 903 207 33 88
+7 967 155 17 70