

A detailed technical drawing of a valve assembly, shown in a perspective view. The drawing is rendered in light blue lines on a white background. It features a central vertical stem with a handle at the top, surrounded by various seals, gaskets, and housing components. The drawing is positioned in the upper left quadrant of the page, with its lines extending towards the center and right. The overall style is clean and professional, typical of engineering or industrial design documentation.

GALA | *Regulating
Systems*

Waterworks

Catalogue2023

List

Butterfly Valves	Fig.2123	Double Flanged Butterfly Valve	1
	Fig.2688	Double Flanged Eccentric Butterfly Valve	3
Gate Valves	Fig.3249	BS NRS Resilient Seat Gate Valve	4
	Fig.3239	BS OS&Y Resilient Seat Gate Valve	5
	Fig.3269	DIN NRS Resilient Seat Gate Valve	6
	Fig.3259	DIN OS&Y Resilient Seat Gate Valve	7
	Fig.3213	OS&Y Metal Seated Gate Valve	8
	Fig.3125	NRS Metal Seated Gate Valve	9
Check Valves	Fig.5113	Counterweight Swing Check Valve	10
	Fig.5117	Oblique Flap Check Valve	11
	Fig.5126	Butterfly Check Valve	12
	Fig.5109	Ball Check Valve	13
Air Valves	Fig.9701	Screwed Air Vent	14
	Fig.9101	Flanged Orifice Air Valve	15
	Fig.9201	Flanged Double Orifice Air Valve	16
	Fig.9301	Combination Air Valve For Sewage Water	17
Knife Gate Valve	Fig.3250	Unidirectional Seal Knife Gate Valve	18
Joint	Fig.GF700	Flange Force Transfer Joint	21
	Fig.GFLEX-F1	Single-Sphere Flexible Rubber Joint with Floating Flanges	22
	Fig.GFLEX-F2	Single-Sphere Rubber Joint with Floating Flanges	25

Double Flanged Butterfly Valve

CLASS 125/PN10/PN16/PN25/JIS 10K

Fig. 2123



Valve Standard :

Comply with ISO 5752/BS 5155/BS EN 593

Pressure Temperature Ratings

Working pressure	10bar/16bar/25bar
Testing Pressure	Shell: 15bar/24bar/37.5bar Seal: 11bar/17.6bar/27.5bar
Working Temperature	-20°C to 110°C EPDM Seat -10°C to 80°C NBR Seat
Suitable Media	Water, Oil & Gas

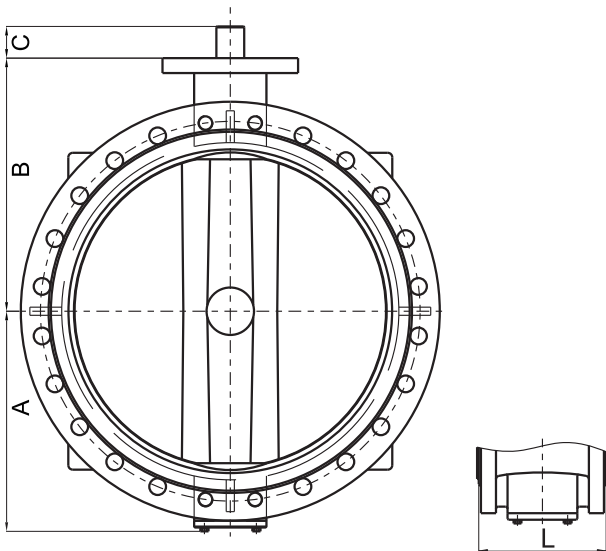

Material Specification

Part	Material	EN Spec.
Body	Ductile Iron	EN-JS 1050
Disc	Ductile Iron	EN-JS 1050
	Bronze	EN 1982 CC491K
	Stainless Steel 304	BS970 304 C 15
	Stainless steel 316	BS970 316 C 16
Shaft	Stainless Steel 410	BS970 410 S 21
	Stainless Steel 431	BS970 431 S 29
Seat Ring	EPDM / NBR	
O-Ring	EPDM / NBR	
Bushing	Bronze	EN 1982 CC491K

Dimensions

DN	mm	50	65	80	100	125	150	200	250	300	350	400	450	500	600	700	750
	inch	2	2-1/2	3	4	5	6	8	10	12	14	16	18	20	24	28	30
A		80	80	95	114	114	139	175	203	242	250	317	341	367	432	488	517
B		110	134	131	150	170	180	210	245	276	328	376	407	433	508	560	610
C		30	30	30	30	30	30	34	34	34	40	52	52	64	70	95	95
L		108	112	114	127	140	140	152	165	178	190	216	222	229	267	292	305

DN	mm	800	900	1000	1200	1300	1350	1400	1500	1600	1800	2000	2200	2400	2600	2800	3000
	inch	32	36	40	48	52	54	56	60	64	72	80	88	96	104	112	120
A		544	615	669	794	968	1062	1066	950	1054	1164	1363	1445	1610	1795	1900	2040
B		620	692	735	917	990	1046	1000	1050	1150	1200	1360	1500	1650	1780	1900	2070
C		95	130	130	150	200	200	200	200	200	200	200	300	300	300	300	350
L		318	330	410	470	490	490	530	570	600	670	760	636/800	850	900	950	1000

Note: Information listed might be subject to change without notice due to continuing products development.

Double Flanged Butterfly Valve

CLASS 125/PN10/PN16/PN25/JIS 10K

Fig. 2123

Appearance

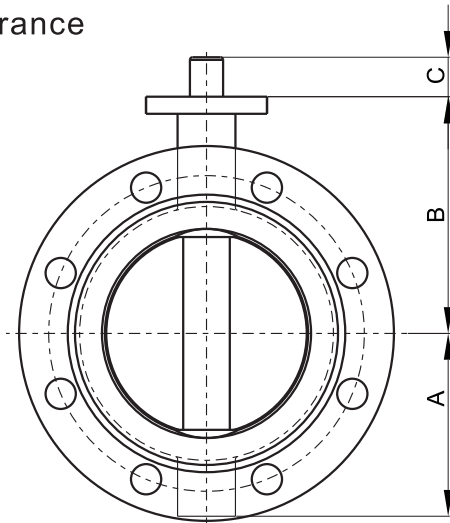

Fit DN50-DN350 Double Flanged Butterfly valves

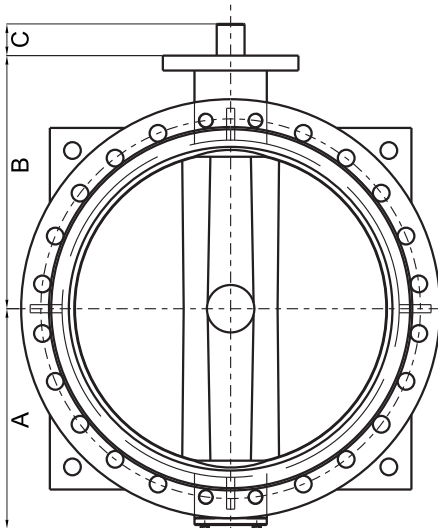

Fit DN400-DN1200 Double Flanged Butterfly valves

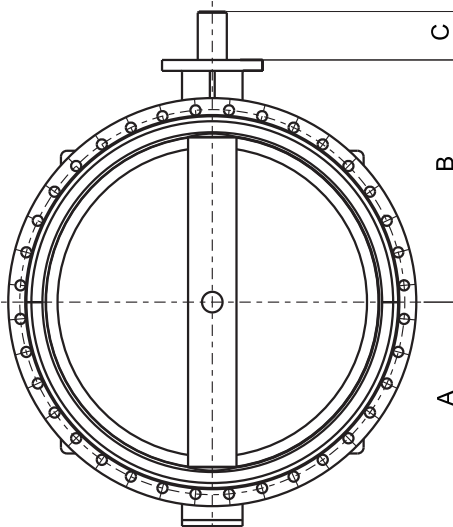

Fit DN1300-DN3000 Double Flanged Butterfly valves

Note: Information listed might be subject to change without notice due to continuing products development.

Double Flanged Eccentric Butterfly Valve

CLASS 125/PN10/PN16/PN25/JIS 10K

Fig. 2688



Valve Standard :

Comply with BS EN 593/EN 1092-2/
BS EN 558/BS EN 1074

Pressure Temperature Ratings

Working pressure	16bar
Testing Pressure	Shell: 15bar
	Seal: 11bar
Working Temperature	-29°C to 80°C
Suitable Media	Water

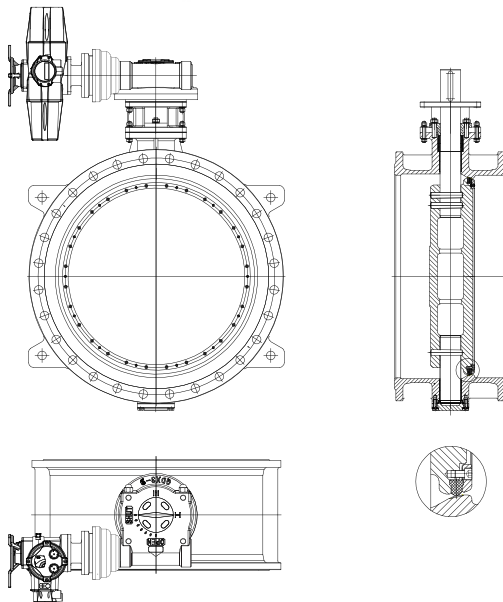

Material Specification

Part	Material	ASTM
Body	Ductile Iron	GGG50
Disc	Ductile Iron	GGG50
Shaft	Stainless Steel	BS970 420S37
Seat	Stainless Steel	A315 CF8-M
Sealing Ring	EPDM	

Dimensions

DN	mm	100	150	200	250	300	350	400	450	500	600	700	800
	inch	4	6	8	10	12	14	16	18	20	24	28	32
L		190	210	230	250	270	290	310	330	350	390	430	470

DN	mm	900	1000	1200	1400	1600	1800	2000	2200	2600	2800	3000	-
	inch	36	40	48	56	64	72	80	88	104	112	120	-
L		510	550	630	710	790	870	950	1000	1200	1300	1400	-

Note: Subject to change without prior notice due to products optimization.

BS NRS Resilient Seat Gate Valve

PN16/PN25

Fig. 3249

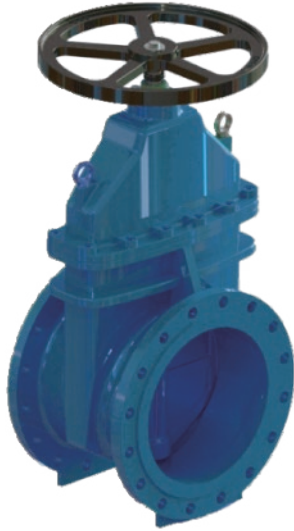

Valve Standard:

Comply with BS 5163 TypeA

Features

- Handwheel or removable square key operated
- Full bore ports avoids the ingress of debris
- Fully encapsulated rubber disc
- Integral stem nut ensuring stem fixing and corrosion prevention
- Working Temperature:-20°C to 110°C(EPDM Seat)
-10°C to 80°C (NBR Seat)

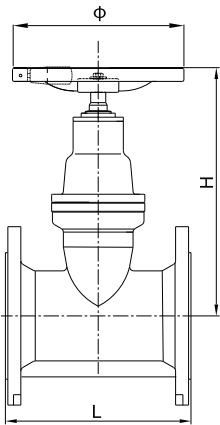

Handwheel Operated

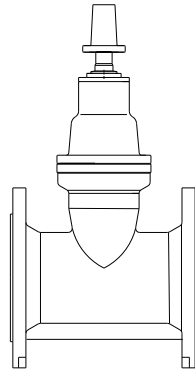

SquareKey Operated(Optional)

Material Specification

Part	Material	ASTM
Body	Ductile Iron	A536 Gr.65-45-12
Bonnet	Ductile Iron	A536 Gr.65-45-12
Disc	Ductile Iron+EPDM/NBR	A536 Gr.65-45-12
Stem	Stainless Steel 410	A276 S410
Stem Nut	Brass	EN 12165 W603W
Hexagon Bolt	Carbon Steel	A216 WCB
O-Ring	EPDM /NBR	
Handwheel	Ductile Iron	A536 Gr.65-45-12

Dimensions

DN	mm	50	65	80	100	125	150	200	250	300	350	400	450	500	600
	inch	2"	2-1/2"	3"	4"	5"	6"	8"	10"	12"	14"	16"	18"	20"	24"
H		230	235	275	315	370	410	540	590	665	785	895	970	1090	1240
L		178	190	203	229	254	267	292	267	356	381	406	432	457	508
Φ		160	160	180	200	250	250	300	350	400	500	500	500	600	600

Note: Subject to change without prior notice due to products optimization.

BS OS&Y Resilient Seat Gate Valve

PN16/PN25

Fig. 3239



Valve Standard:

Comply with BS 5163

Features

- Full bore ports avoids the ingress of debris
- Fully encapsulated rubber disc
- Integral stem nut ensuring stem fixing and corrosion prevention
- Working Temperature: -20°C to 110°C (EPDM Seat)
-10°C to 80°C (NBR Seat)

Material Specification

Part	Material	ASTM
Body	Ductile Iron	A536 Gr.65-45-12
Bonnet	Ductile Iron	A536 Gr.65-45-12
Disc	Ductile Iron+EPDM/NBR	A536 Gr.65-45-12
Stem	Stainless Steel 410	A276 S410
Stem Nut	Brass	EN 12165 W603W
Hexagon Bolt	Carbon Steel	A216 WCB
O-Ring	EPDM /NBR	
Handwheel	Ductile Iron	A536 Gr.65-45-12

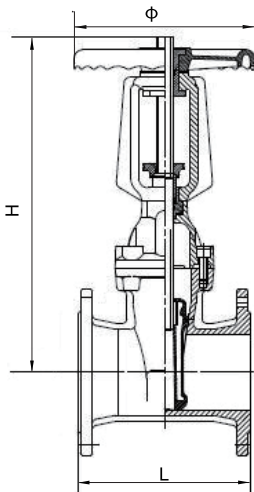

Dimensions

DN	mm	50	65	80	100	125	150	200	250	300	350	400
	inch	2"	2-1/2"	3"	4"	5"	6"	8"	10"	12"	14"	16"
H		350	380	455	548	618	747	942	1144	1328	1410	1685
L		178	190	203	229	254	267	292	267	356	381	406
Φ		160	160	180	200	250	250	300	350	400	500	500

Note: Subject to change without prior notice due to products optimization.

DIN NRS Resilient Seat Gate Valve

PN16

Fig. 3269

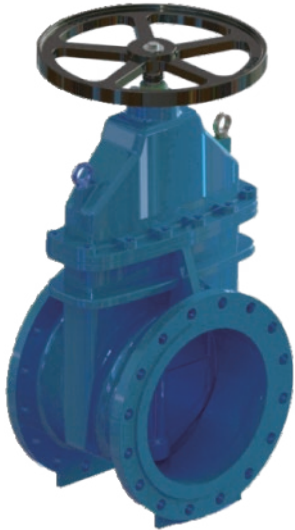

Valve Standard:

Comply with DIN3352 F4/F5

Features

- Handwheel or removable square key operated
- Full bore ports avoids the ingress of debris
- Fully encapsulated rubber disc
- Integral stem nut ensuring stem fixing and corrosion prevention
- Working Temperature: -20°C to 110°C (EPDM Seat)
-10°C to 80°C (NBR Seat)

Material Specification

Part	Material	ASTM
Body	Ductile Iron	A536 Gr.65-45-12
Bonnet	Ductile Iron	A536 Gr.65-45-12
Disc	Ductile Iron+EPDM/NBR	A536 Gr.65-45-12
Stem	Stainless Steel 410	A276 S410
Stem Nut	Brass	EN 12165 W603W
Hexagon Bolt	Carbon Steel	A216 WCB
O-Ring	EPDM /NBR	
Handwheel	Ductile Iron	A536 Gr.65-45-12

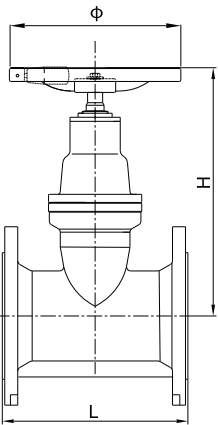

Handwheel Operated

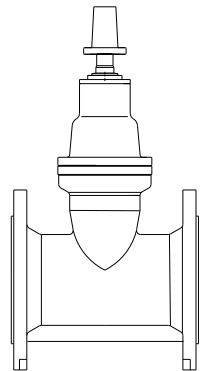

SquareKey Operated(Optional)

Dimensions

DN	mm	50	65	80	100	125	150	200	250	300	350	400	450	500	600
	inch	2"	2-1/2"	3"	4"	5"	6"	8"	10"	12"	14"	16"	18"	20"	24"
H		230	235	275	315	370	410	510	590	665	785	895	970	1090	1240
L		150	170	180	190	200	210	230	250	270	290	310	330	350	390
φ		160	160	180	200	250	250	300	350	400	500	500	500	600	600

Note: Subject to change without prior notice due to products optimization.

DIN NRS Resilient Seat Gate Valve

PN16

Fig. 3259



Valve Standard:

Comply with DIN3352 F4/F5

Features

- Handwheel or removable square key operated
- Full bore ports avoids the ingress of debris
- Fully encapsulated rubber disc
- Integral stem nut ensuring stem fixing and corrosion prevention
- Working Temperature:-20°C to 110°C(EPDM Seat)
-10°C to 80°C (NBR Seat)

Material Specification

Part	Material	ASTM
Body	Ductile Iron	A536 Gr.65-45-12
Bonnet	Ductile Iron	A536 Gr.65-45-12
Disc	Ductile Iron+EPDM/NBR	A536 Gr.65-45-12
Stem	Stainless Steel 410	A276 S410
Stem Nut	Brass	EN 12165 W603W
Hexagon Bolt	Carbon Steel	A216 WCB
O-Ring	EPDM /NBR	
Handwheel	Ductile Iron	A536 Gr.65-45-12

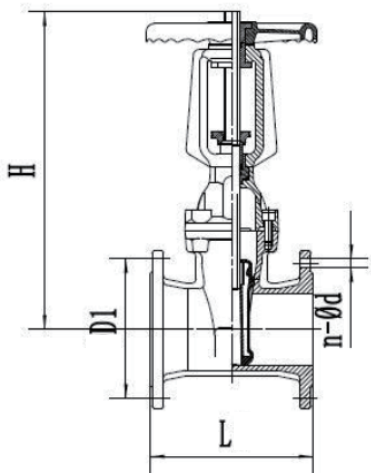

Dimensions

DN	mm	50	65	80	100	125	150	200	250	300	350	400
	inch	2"	2-1/2"	3"	4"	5"	6"	8"	10"	12"	14"	16"
H		350	380	455	548	618	747	942	1144	1328	1410	1685
L		150	170	180	190	200	210	230	250	270	290	310
D1		125	145	160	180	210	240	295	355	410	470	525
n-Ød		4-Ø19	4-Ø19	8-Ø19	8-Ø19	8-Ø19	8-Ø23	12-Ø23	12-Ø28	12-Ø28	16-Ø28	16-Ø31

Note: Subject to change without prior notice due to products optimization.

OS&Y Metal Seated Gate Valve
PN16/PN25

Fig. 3213



Valve Standard :
Comply with DIN 3352 F4

Pressure Temperature Ratings

Working pressure	10bar/16bar
Testing Pressure	Shell:15bar/24bar Seal:11bar/17.6bar
Working Temperature	-10°C to 120°C

Material Specification

Part	Material	EN Spec.
Body	Cast Iron	EN-JL1040
	Ductile Iron	EN-JS1050
Bonnet	Cast Iron	EN-JL1040
	Ductile Iron	EN-JS1050
Disc	Cast Iron	EN-JL1040
	Ductile Iron	EN-JS1050
Seat Ring	Brass	EN 12165 W603N
Stem	Stainless Steel	BS970 420S37
Packing	Graphite	Non-Asbestos
Hand Wheel	Cast Iron	EN-JL1040

Note :
DI Body For PN16

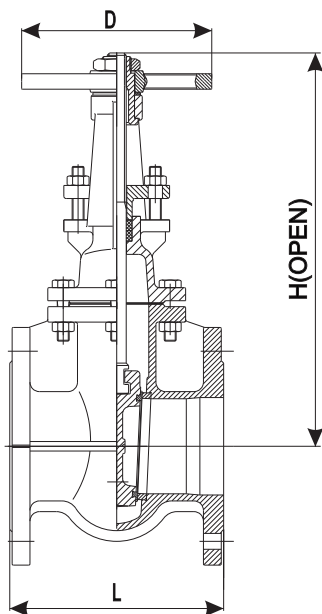

Dimensions

DN	mm	40	50	65	80	100	125	150	200	250	300
	inch	1-1/2	2	2-1/2	3	4	5	6	8	10	12
L		140	150	170	180	190	200	210	230	250	270
H		295	315	371	424	500	598	711	901	1093	1273
D		160	160	160	160	200	200	250	250	320	320

Note: Information listed might be subject to change without notice due to continuing products development.

NRS Metal Seated Gate Valve
PN10/PN16

Fig. 3125

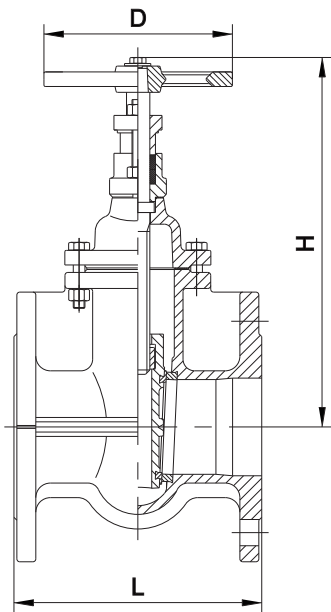

Valve Standard :

Comply with DIN 3352 (F4)

Pressure Temperature Ratings

Working pressure	10bar/16bar
Testing Pressure	Shell: 15bar/24bar
	Seal: 11bar/17.6bar
Working Temperature	-10°C to 120°C

Material Specification

Part	Material	EN Spec.
Body	Cast Iron	EN-JL1040
	Ductile Iron	EN-JS1050
Bonnet	Cast Iron	EN-JL1040
	Ductile Iron	EN-JS1050
Disc	Cast Iron	EN-JL1040
	Ductile Iron	EN-JS1050
Seat Ring	Brass	EN 12165 W603N
Stem	Brass	EN 12165 W603N
	Stainless Steel	BS970 420S37
Packing	Graphite	Non-Asbestos
Hand Wheel	Cast Iron	EN-JL1040

Note :

DI Body For PN16

Dimensions

DN	mm	40	50	65	80	100	125	150	200	250	300
	inch	1-1/2	2	2-1/2	3	4	5	6	8	10	12
L		140	150	170	180	190	200	210	230	250	270
H		245	255	277	303	340	387	454	538	629	730
D		130	130	130	150	185	185	195	225	245	285

Note: Information listed might be subject to change without notice due to continuing products development.

Counterweight Swing Check Valve
PN16

Fig. 5113



Valve Standard :
Face to Face Dimension comply with EN558-2 series 10

Pressure Temperature Ratings

Working pressure	16bar
Testing Pressure	Shell: 24bar Seat: 16 bar
Working Temperature	-10°C to 120°C
Suitable Medium	Water, oil, steam

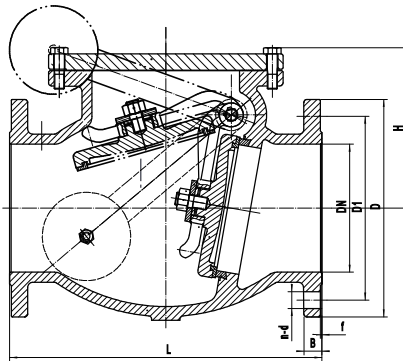

Material Specification

Part	Material	BS Spec.
Body	Cast Iron	BS EN 1561 EN-GJL-250
Bonnet	Cast Iron	BS EN 1561 EN-GJL-250
Disc	Cast Iron	BS EN 1561 EN-GJL-250
Seat Ring	Cast Bronze	BS 1400 LG2
Gasket	Graphite	
Hanger	Ductile Cast Iron	BS EN1563 GJS150-10
Pin	Stainless Steel	BS 970 304S15
Washer	Steel	BS 970 43A
O-Ring	EPDM	

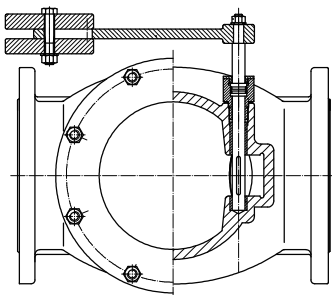

Dimensions

DN	mm	50	65	80	100	125	150	200	250	300	350	400	450	500	600
	inch	2	2-1/2	3	4	5	6	8	10	12	14	16	18	20	24
L		203	216	241	292	330	356	495	622	699	787	914	914	1016	1219
D		165	185	200	220	250	285	340	405	460	520	580	640	715	840
D1		125	145	160	180	210	240	295	355	410	470	525	585	650	770
D2		99	118	132	156	184	211	266	319	370	429	480	548	609	720
B		20	20	22	24	26	26	30	32	32	36	38	40	42	48
n-d		4-19	4-19	8-19	8-19	8-19	8-23	12-23	12-28	12-28	16-28	16-31	20-31	20-34	20-37
f		3	3	3	3	3	3	3	3	4	4	4	4	4	5
H		103	120	141	162	187	211	270	316	357	560	589	645	702	812

Note: Information listed might be subject to change without notice due to continuing products development.

Swing Check Valve

PN16

Fig. 5117

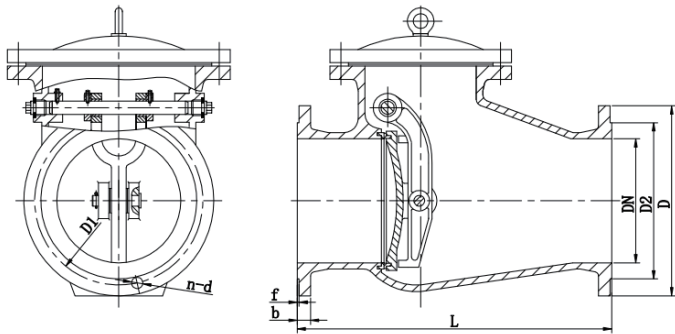

Valve Standard:

Face to Face Standard: BS 5153
 Flanged Standard: BS EN 1092-2:1997 PN16
 Tests Standard: BS EN 12266-1:2003 Rate B

Pressure Temperature Ratings

Working pressure	6bar ~ 25bar
Testing Pressure	Shell: 24bar Seal: 17.6bar
Working Temperature	≤80°C
Suitable Media	Water

Material Specification

Part	Material	ASTM
Body	Ductile Iron	A536 Gr.65-45-12
Bonnet	Ductile Iron	A536 Gr.65-45-12
Disc	Ductile Iron	A536 Gr.65-45-12
Sealing Ring	Bronze	
Bush	Stainless Steel 304	A351 CF8
Shaft	Stainless Steel 420	BS970 420S37
Gasket	EPDM	
Lever&Weight	Carbon Steel+Gray Iron	

Dimensions

DN	mm	300	350	400	450	500	600	700	800
	inch	12	14	16	18	20	24	28	32
D		460	520	580	640	715	840	910	1025
D1		410	470	525	585	650	770	840	950
D2		370	429	480	548	609	720	794	901
b		25	27	28	30	32	36	40	43
f		4	4	4	4	4	5	5	5
n-d		12-ø28	16-ø28	16-ø31	20-ø31	20-ø34	20-ø37	24-ø37	24-ø41
L		698	787	914	965	1067	1219	1500	1700

DN	mm	900	1000	1100	1200	1300	1400	1500	1600
	inch	36	40	44	48	52	56	60	64
D		1125	1255	1355	1485	1585	1685	1820	1930
D1		1050	1170	1270	1390	1490	1590	1710	1820
D2		1001	1112	1218	1328	1430	1530	1640	1750
b		47	50	54	57	60	60	63	65
f		5	5	5	5	5	5	5	5
n-d		28-ø41	28-ø41	32-ø44	32-ø50	32-ø50	36-ø50	36-ø57	40-ø57
L		1900	1510	1600	1700	1800	1800	1900	2000

Note: Subject to change without prior notice due to products optimization.

Butterfly Check Valve

PN10/PN16

Fig. 5117

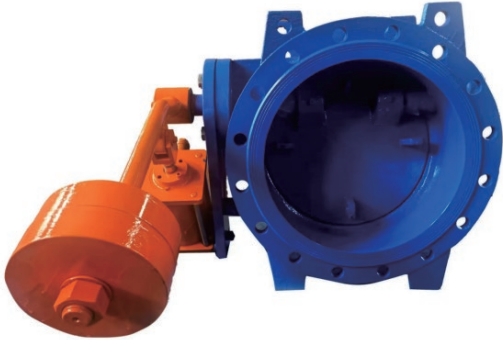

Valve Standard:

Design acc.To:AWWA C512/EN1074-4/CJ-T 217

Flange Standard:EN1092,B16.5

Testing acc.To:EN1074-1&4/EN12266

Working Pressure:PM10/16,CLASS 125/150

Pressure Temperature Ratings

Working Pressure	10 bar /16 bar
Testing Pressure	Shell: 15/24bar Seal:11/17.6bar
Working Temperature	0°C to 80°C
Suitable Media	Water&Gas

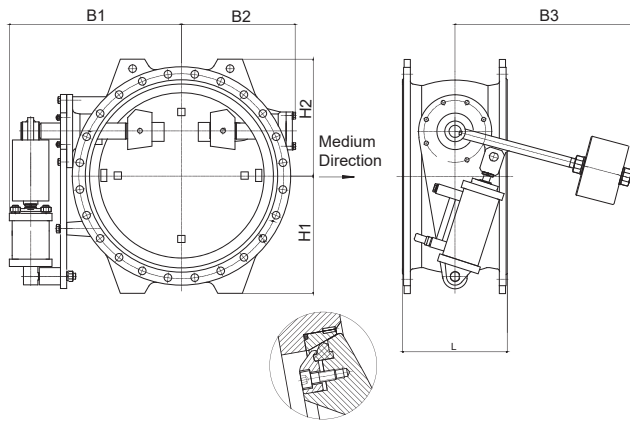

Material Specification

Part	Material	ASTM
Body	Ductile Iron	GGG50
Disc	Ductile Iron	GGG50
Pin	Stainless Steel 420	BS970 420S37
Lever	Carbon Steel	A126 WCB
Shaft	Stainless Steel 420	BS970 420S37
Lever	Carbon Steel	A126 WCB
Seat Ring	Stainless Steel 304	A351 CF8
Seal	NBR / EPDM	
O-Ring	NBR / EPDM	

Dimensions

DN	mm	300	350	400	450	500	600	700	1200
	inch	12	14	16	18	20	24	28	48
B1		670	715	730	750	780	815	725	955
B2		265	310	325	350	380	415	465	732
B3		560	560	560	560	990	990	1030	1320
H1		250	270	300	330	360	420	480	760
H2		250	270	300	330	360	420	480	760
L		270	290	310	330	350	390	430	630

Note: Subject to change without prior notice due to products optimization.

Ball Check Valve

PN10/PN16

Fig. 5109



Valve Standard:

Face to face standard conforms to DIN-6

Flange connection conforms to BS EN1092-2 PN10/PN16

Pressure Temperature Ratings

Working pressure	10bar / 16bar
Testing Pressure	Shell: 15bar / 24bar
	Seal: 11bar / 17.6bar

Material Specification

Part	Material	Specification
Body	Ductile Iron	GGG50
Ball	Carbon Steel/Iron + EPDM	-
Bonnet	Ductile Iron	GGG50
Gasket	EPDM/NBR	-
Bolt	Steel	C45E/1045

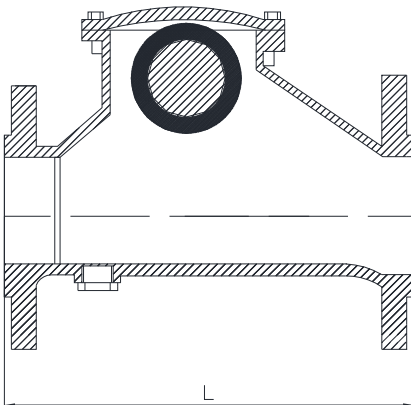

Dimensions (mm)

DN	mm	50	65	80	100	125	150	200	250	300
	inch	2	2-1/2	3	4	5	6	8	10	12
L		200	240	260	300	350	400	500	600	700

Note: Information listed might be subject to change without notice due to continuing products development.

Screwed Air Vent

CLASS 125/PN16/JIS10K

Fig. 9701

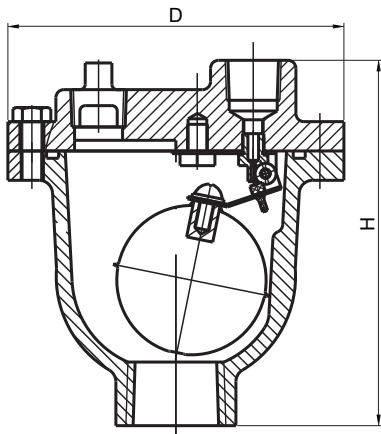

Pressure Temperature Ratings

Working pressure	16bar
Testing Pressure	Shell:24bar
	Seal:17.6bar
Working Temperature	-10°C to 100°C

Material Specification

Part	Material	ASTM Spec.
Body	Cast Iron	A126 Class B
	Ductile Iron	A536 65-45-12
Cover	Cast Iron	A126 Class B
	Ductile Iron	A536 65-45-12
Seat Plug	Viton/EPDM	Commercial
Float	Stainless Steel	AISI 304
Float Arm	Stainless Steel	AISI 304
Orifice Button	Viton	Commercial

Dimensions

DN		Inlet	Outle	Orifice	D	H
mm	inch					
15	1/2	15	15	1.6	125	137
20	3/4	20	15	1.6	125	137
25	1	25	15	1.6	125	137

Note: Information listed might be subject to change without notice due to continuing products development.

Flanged Orifice Air Valve

CLASS 125/PN16/JIS10K

Fig. 9101

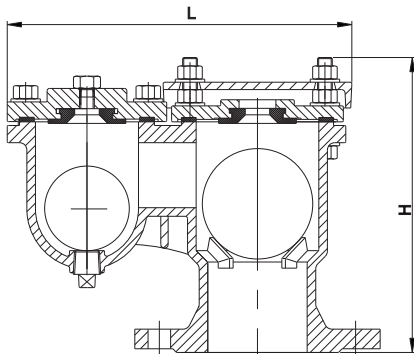
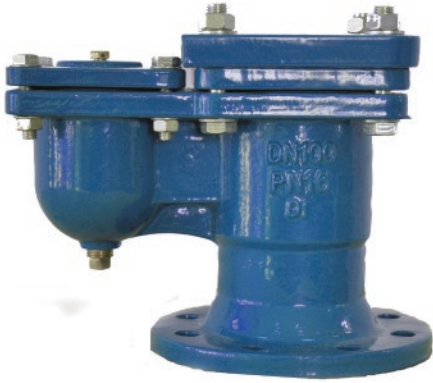

Pressure Temperature Ratings

Working pressure	16bar
Testing Pressure	Shell:24bar
	Seal:17.6bar
Working Temperature	-10°C to 100°C

Material Specification

Part	Material	EN Spec.
Body	Ductile Iron	EN-JS1050
Orifice Cover	Ductile Iron	EN-JS1050
Air Release Nipple	Brass	EN 12165 CW603N
Screw Plug	Brass	EN 12165 CW603N
Float Ball	ABS (ISO2580)	Commercial
Ball Seal Orifice	EPDM	Commercial

Dimensions

DN	mm	40	50	65	80	100	125	150	200	250
	inch	1-1/2	2	2-1/2	3	4	5	6	8	10
L		224	273	273	283	302	353	353	433	491
H		187	214	214	244	270	323	323	401	450

Note: Information listed might be subject to change without notice due to continuing products development.

Flanged Double Orifice Air Valve

CLASS 125/PN16/JIS 10K

Fig. 9201

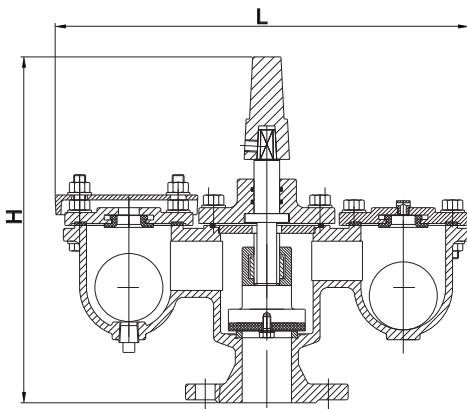

Pressure Temperature Ratings

Working pressure	16bar
Testing Pressure	Shell:24bar
	Seal:17.6bar
Working Temperature	-10°C to 100°C

Material Specification

Part	Material	EN Spec.
Body	Ductile Iron	EN-JS1050
Orifice Cover	Ductile Iron	EN-JS1050
Air Release Nipple	Brass	EN 12165 CW603N
Screw Plug	Brass	EN 12165 CW603N
Float Ball	ABS (ISO2580)	Commercial
Ball Seal Orifice	EPDM	Commercial

Dimensions

DN	mm	50	80	100	150	200
	inch	2	3	4	6	8
L		418	454	492	595	698
H		351	375	419	440	475

Note: Information listed might be subject to change without notice due to continuing products development.

Combination Air Valve For Sewage Water

PN16

Fig. 9301



Valve Standard:

Design acc.To:AWWA C512/EN1074-4/CJ-T 217
 Flange Standard:EN1092,B16.5
 Testing acc.To:EN1074-1&4/EN12266
 Working Pressure:PM10/16,CLASS 125/150

Advantage

- Combination type,high speed air release,triple function
- Full stainless steel suits for sewerage liquid

Material Specification

Part	Material	ASTM
Body	Stainless Steel 304	A351 CF8
	Stainless Steel 316	A351 CF8M
	Carbon Steel	A126 WCB
Float	Stainless Steel 304	A351 CF8
	Stainless Steel 316	A351 CF8M
Kineaic Bar	Stainless Steel 304	A351 CF8
	Stainless Steel 316	A351 CF8M
Top Flange	Stainless Steel 304	A351 CF8
	Stainless Steel 316	A351 CF8M
	Stainless Steel	UHMW
	Carbon Steel	A126 WCB
Gasket	NBR / VITON	
Sealing Seat	EPDM / NBR	
Up Vent Float	UHMW	
Up Valve Body	ABS	

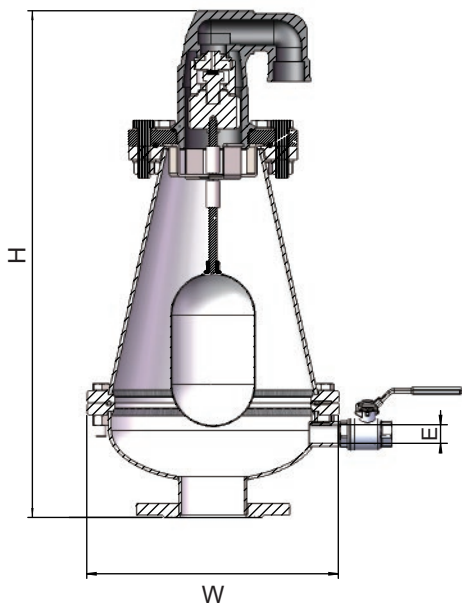

Dimensions

DN	mm	50	80	100	150
	inch	2	3	4	6
H		640	640	640	640
W		291	291	291	291
E		1-1/2"	1-1/2"	1-1/2"	1-1/2"
K		855	855	855	855
A		12.56	12.56	12.56	12.56

Note: Subject to change without prior notice due to products optimization.

Unidirectional Seal Knife Gate Valve

PN16

Fig. 3250



Valve Standard

Design Standard: MSS SP-81
 Face to Face Standard: MSS SP-81
 Testing Standard: API-598

Working Pressure

DN50-DN100 16bar
 DN125-DN200 14bar
 DN250-DN300 12Bar
 DN350-DN400 10bar

Flange Connection Standard

DIN 2632 PN10, PN16,
 ANSI 150LB, JIS 10K, TABLE E/D

Materials List

Code	Name	Material
1	Handle Cover	Q235+Painting
2*	Hand Wheel	GGG40
3	Bearing	ZChSnSb10-6
4	Stem Nut	Brass
5	Stem	2Cr13/SS304/SS316
6	Disc	SS304/SS316/F55/2205
7	Yoke	Q235
8	Seat	EPDM/NBR/PTFE/Metal
9	Seat Cover	SS304/SS316
10	Yoke Head	GGG40
11	Packing Gland	WCB/CF8
12	Packing	Aramid PTFE
13	Bolt	Fe+Zn With Painting/SS304
14	Body	WCB/GGG40/CF8/CF8M

Remark: * electric, pneumatic, hydraulic, sprocket, electro-hydraulic, gear available

Features

- Unidirectional Sealing
- 1PC Body design
- Full port design
- Mixed with a variety of materials packing

Note: Information listed might be subject to change without notice due to continuing products development.

Unidirectional Seal Knife Gate Valve

PN16

Fig. 3250

Dimensions(mm)

For Flange Connection End DIN2632 PN10

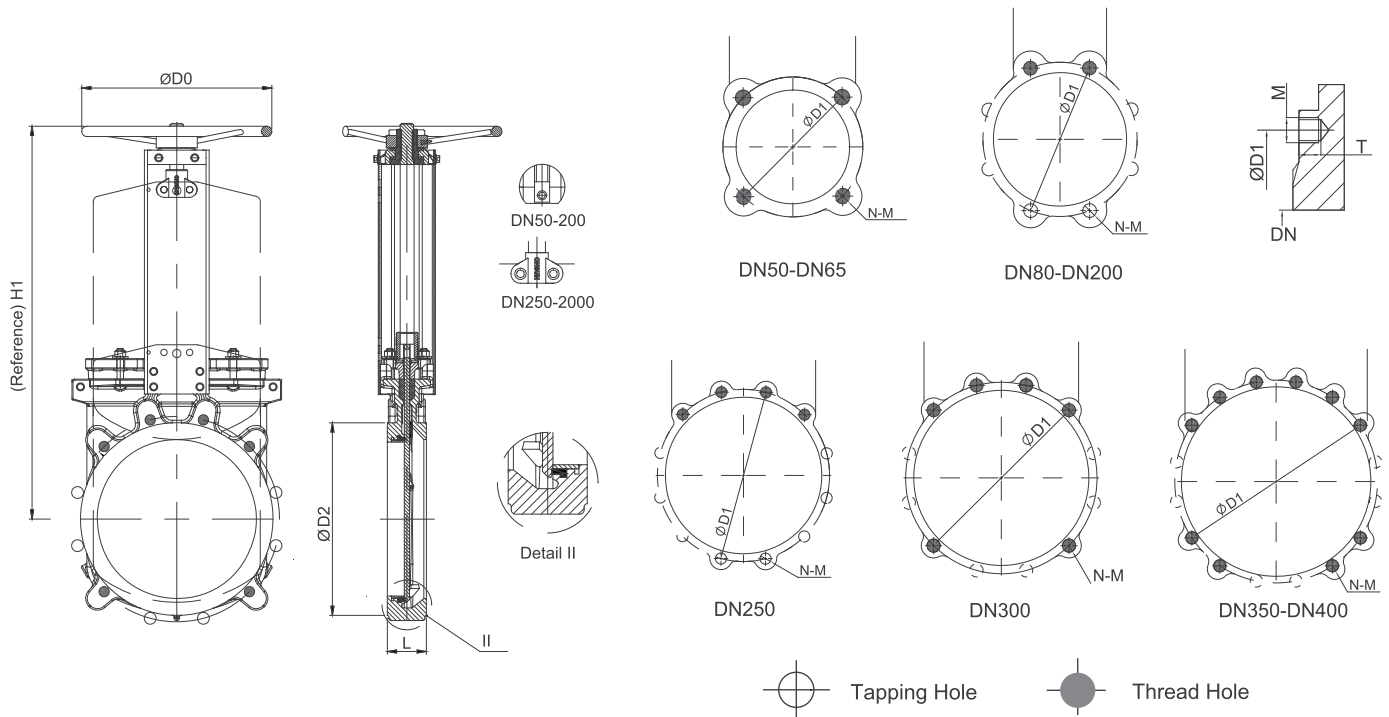

DN	L	D0	D1	D2	H1	N	M	T	Thread Hole	Tapping Hole
2"(DN50)	48	180	125	99	260	4	M16	13	2	2
2-1/2"(DN65)	48	200	145	118	292	4	M16	13	2	2
3"(DN80)	51	200	160	132	320	8	M16	13	2	6
4"(DN100)	51	240	180	156	358	8	M16	13	2	6
5"(DN125)	57	260	210	184	395	8	M16	16	2	6
6"(DN150)	57	280	240	211	450	8	M16	16	2	6
8"(DN200)	70	300	295	266	532	8	M20	20	2	6
10"(DN250)	70	320	350	319	670	12	M20	20	4	8
12"(DN300)	76	350	400	370	758	12	M20	20	6	6
14"(DN350)	76	400	460	429	857	16	M20	20	10	6
16"(DN400)	89	450	515	480	946	16	M24	24	10	6

Note: Information listed might be subject to change without notice due to continuing products development.

Unidirectional Seal Knife Gate Valve

PN16

Fig. 3250

Dimensions(mm)

For Flange Connection End ANSI 150LB

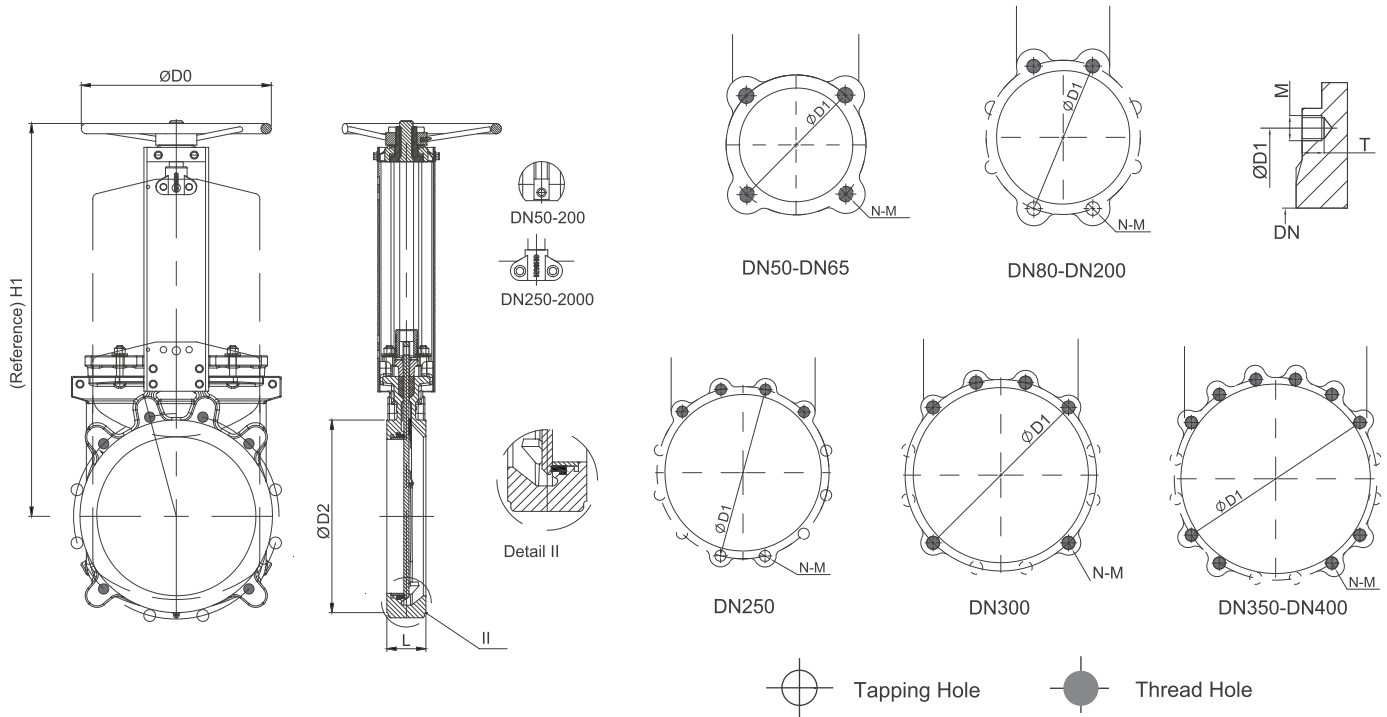

DN	L	D0	D1	D2	H1	N	M	T	Thread Hole	Tapping Hole
2"(DN50)	48	180	121	99	260	4	M5/8-11	13	2	2
2-1/2"(DN65)	48	200	140	118	292	4	M5/8-11	13	2	2
3"(DN80)	51	200	153	132	320	4	M5/8-11	13	2	2
4"(DN100)	51	240	191	156	358	8	M5/8-11	13	2	6
5"(DN125)	57	260	216	184	395	8	M3/4-10	16	2	6
6"(DN150)	57	280	242	211	450	8	M3/4-10	16	2	6
8"(DN200)	70	300	299	266	532	8	M3/4-10	20	2	6
10"(DN250)	70	320	362	319	670	12	M7/8-9	20	6	6
12"(DN300)	76	350	432	370	758	12	M7/8-9	20	6	6
14"(DN350)	76	400	476	429	857	12	M1-8	20	10	6
16"(DN400)	89	450	540	480	946	16	M1-8	24	10	6

Note: Information listed might be subject to change without notice due to continuing products development.

Flange Force Transfer Joint

PN16

Fig. GF700



Material Specification

Part	Material
Body	WCB
O-Ring	NBR/EPDM
Gland	WCB
Flange	WCB
Bolt	Galvanized
Nut	Galvanized

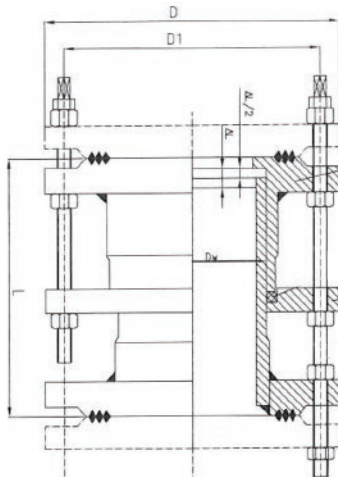

Dimensions

DN	mm	50	65	80	100	125	150	200	250	300	350	400	450
	inch	12	12	14	12	12	14	12	12	14	12	12	14
D		165	185	200	220	250	285	340	405	460	520	580	640
D1		125	145	160	180	210	240	295	355	410	470	525	585
n-d0		560	560	560	560	560	560	560	560	560	560	560	560
L		200	200	200	200	200	200	200	200	220	220	220	220

DN	mm	500	600	700	800	900	1000	1200	1400	1600	1800	2000	2200
	inch	14	12	12	14	12	12	14	12	12	14	12	12
D		715	840	910	1025	1125	1255	1485	1685	1930	2130	2345	2555
D1		650	770	840	950	1050	1170	1390	1590	1820	2020	2230	2440
n-d0		560	560	560	560	560	560	560	560	560	560	560	560
L		220	240	240	350	350	350	370	370	380	380	400	400

Note: Information listed might be subject to change without notice due to continuing products development.

Single-Sphere Flexible Rubber Joint with Floating Flanges

PN16/PN25

Fig. GFLEX-F1



Features

Achievements

Having been used in more than 20 countries for over 30 years, GALA brand products proudly demonstrate their popularity.

Reliability

Unparalleled durability is guaranteed by the distinctive and strict design standards of GALA

Quality

Manufactured in GALA's own factory under thorough control with ISO9000 quality management system.

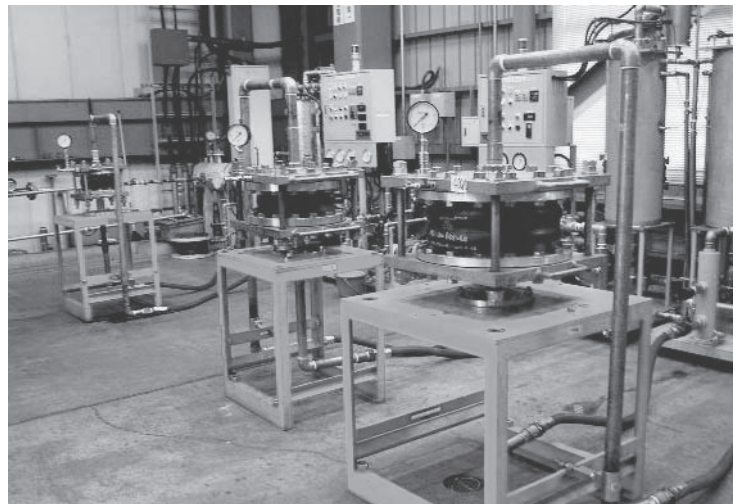
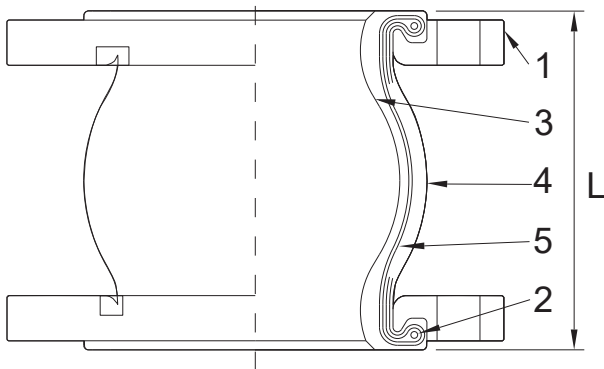

Materials

No.	Parts	Materials
1	Flange	Ductile Iron (32 - 300) Mild Steel (350-600)
2	Reinforcing Ring	Carbon Steel
3	Inner Rubber	EPDM
4	Outer Rubber	EPDM
5	Reinforcing Cord	Nylon

Flanges on ANSI, BS, etc. available.
The flange material can be changed to Mild Steel, SUS304 and SUS316. Please consult us.
JIS16K / JIS20K Flanges are all Mild steel (32~600).

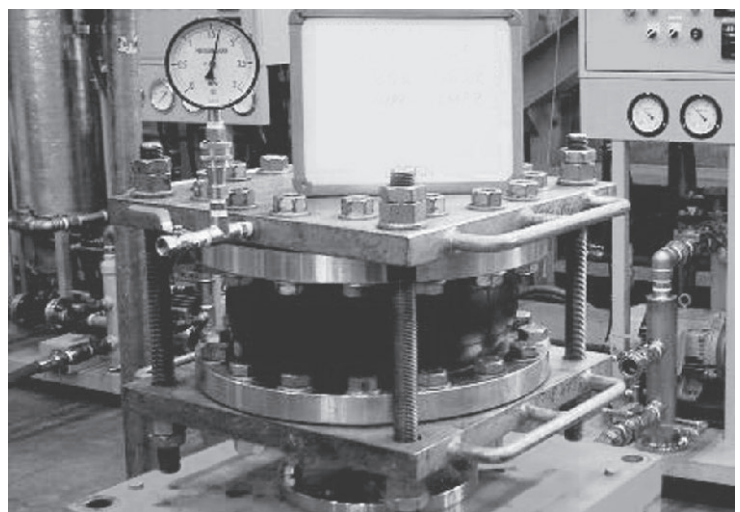

Note: Information listed might be subject to change without notice due to continuing products development.

Single-Sphere Flexible Rubber Joint with Floating Flanges

PN16/PN25

Fig. GFLEX-F1

Operating Conditions and Performance

Working Temperature vs. Working Pressure

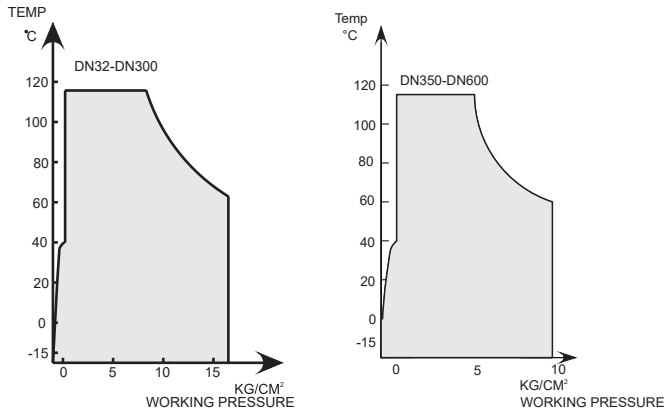

Applications

This product is mainly applicable for piping systems in commercial and industrial buildings and plants.

Applicable fluids are exclusively water including cold water, warm water, cooled water, sea water, etc.

This product can not be used for drinking water, pool water, oil, or boiled water.

Technical Parameters

Size	Operating Pressure	Bursting Pressure	Vacuum Rating	Temperature
	Psig(kg/Sqcm)	Psig(kg/Sqcm)	mmHg	°C
DN32~DN300	225(16)	682(48)	750	-15~115
DN350~DN600	125(8.6)	435(30)	500	-15~115

Dimensions and Displacement Values

Nominal Diameter		Dimensions	Axial Displacement		Lateral Displacement	Angle of Deflection
DN (mm)	Inch	mm L	Stretch	Compression		(Bilateral)
32	1-1/4	95	6	10	9	15°
40	1-1/2	95	6	10	9	15°
50	2	105	7	10	10	15°
65	2-1/2	115	8	13	12	15°
80	3	130	8	15	12	15°
100	4	135	8	15	12	15°
125	5	170	12	19	15	15°
150	6	180	12	20	15	10°
200	8	205	12	20	22	10°
250	10	230	16	28	22	10°
300	12	245	16	28	25	10°
350	14	265	16	28	25	10°
400	16	265	16	28	25	10°
450	18	265	16	28	25	10°
500	20	265	16	28	25	10°
600	24	265	16	28	25	10°

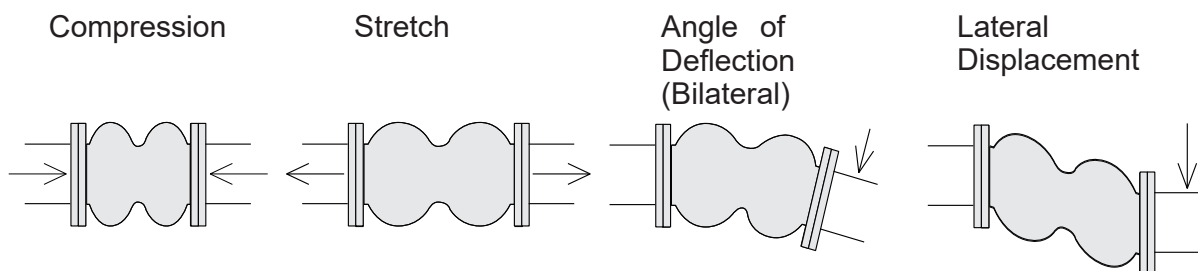

Note: Information listed might be subject to change without notice due to continuing products development.

Single-Sphere Flexible Rubber Joint with Floating Flanges

PN16/PN25

Fig. GFLEX-F1

Operating Conditions

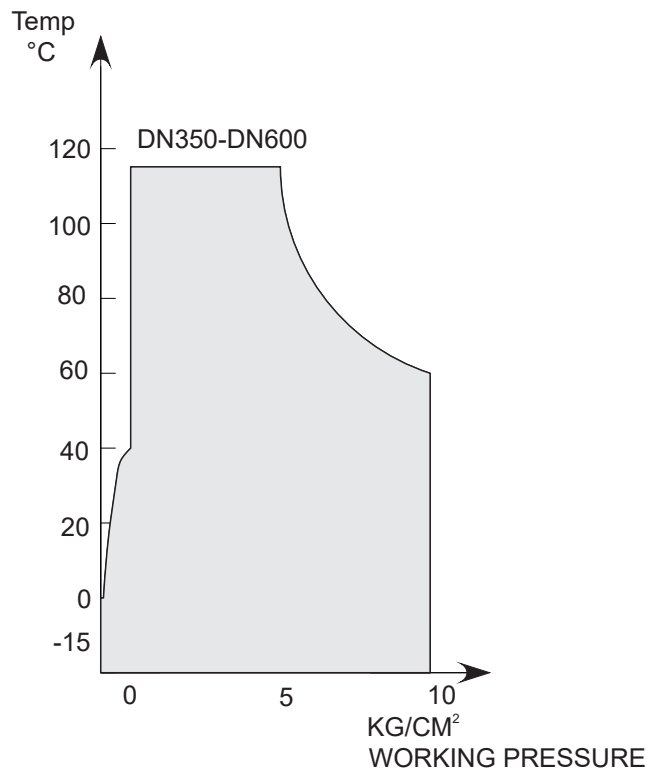
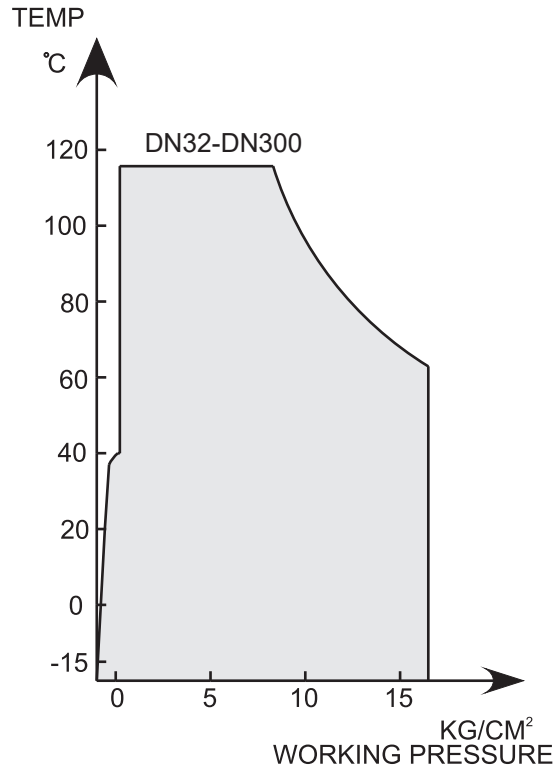

Note: Information listed might be subject to change without notice due to continuing products development.

Twin Sphere Rubber Joint with Floating Flanges

PN16/PN25

Fig. GFLEX-F2



Features

Fit for suction and delivery (discharge)

Additional Features and Benefits

1. Additional gaskets and/or packing are not required.
2. Simplified installation in all piping systems using easy alignment flanges.
3. Ability to absorb considerable elongation and compression of pipes caused by temperature changes prevents piping system breaks and equipment down time.
4. Absorbs the force created by pulsating water and reduces the effect of water hammer.

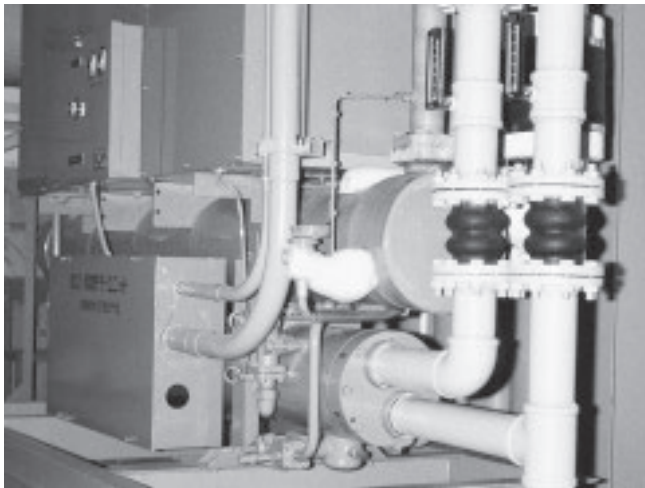

Typical Applications

1. Cold and warm water pressure piping systems in commercial and industrial buildings and plants.
2. Pump and turbine piping used for power generation plants, industrial machinery and pump blowers.
3. Feed-water and drainage piping for water, wastewater, and sanitary system.

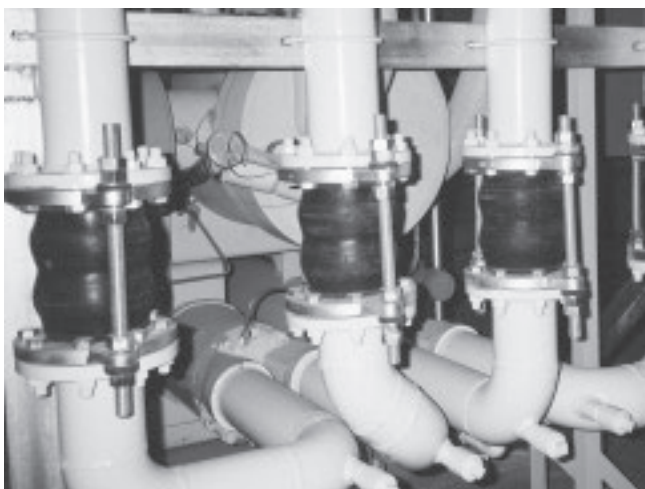

Note: FLEXIBLE RUBBER JOINT is not applicable for use with oil, air gases, hot water supply lines and with pool water.

Note: Information listed might be subject to change without notice due to continuing products development.

Twin Sphere Rubber Joint with Floating Flanges

PN16/PN25

Fig. GFLEX-F2

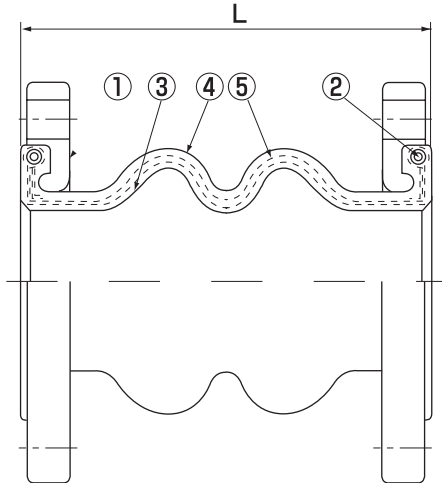

Materials

No.	Parts	Materials
1	Flange	Ductile Iron (32 - 300) Mild Steel (350-600)
2	Reinforcing Ring	Carbon Steel
3	Inner Rubber	EPDM
4	Outer Rubber	EPDM
5	Reinforcing Cord	Nylon

Flanges on ANSI, BS, etc. available.
The flange material can be changed to Mild Steel, SUS304 and SUS316. Please consult us.
JIS16K / JIS20K Flanges are all Mild steel (32~600).

Technical Parameters

Size	Operating Pressure	Bursting Pressure	Vacuum Rating	Temperature
	Psig(kg/Sqcm)	Psig(kg/Sqcm)	mmHg	°C
DN32~DN300	225(16)	682(48)	500	-15~115
DN350~DN600	125(8.6)	435(30)	400	-15~115

Dimensions and Displacement Values

Nominal Diameter		Dimensions mm L	Axial Displacement mm		Lateral Displacement	Angle of Deflection (Bilateral)
DN (mm)	Inch		Stretch	Compression		
32	1-1/4	175	20	30	45	30°
40	1-1/2	175	20	30	45	30°
50	2	175	20	30	45	30°
65	2-1/2	175	25	50	45	30°
80	3	175	25	50	45	30°
100	4	225	35	50	35	30°
125	5	225	35	50	35	30°
150	6	225	35	50	35	30°
200	8	325	35	50	30	30°
250	10	325	35	50	30	15°
300	12	325	35	50	30	15°
350	14	345	25	40	28	10°
400	16	345	25	40	28	10°
450	18	345	25	40	28	10°
500	20	345	25	40	28	10°
600	24	345	25	40	28	10°

Note: Information listed might be subject to change without notice due to continuing products development.

Twin Sphere Rubber Joint with Floating Flanges

PN16/PN25

Fig. GFLEX-F2

Fig.GFLEX-F2

Operating Conditions

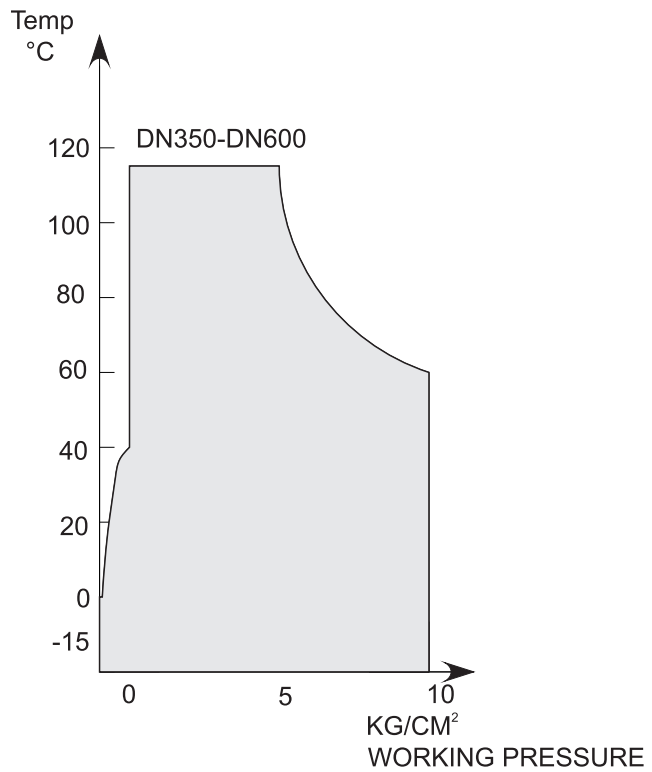
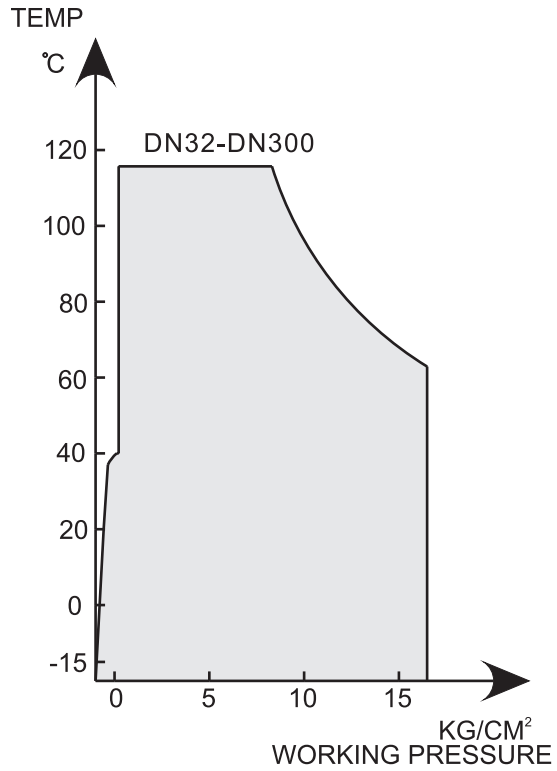

Note: Information listed might be subject to change without notice due to continuing products development.

GALA | *Regulating Systems*